

HP Archive

This vintage Hewlett Packard document was
preserved and distributed by

[www. hparchive.com](http://www.hparchive.com)

Please visit us on the web !

On-line curator: Tony Gerbic

DUAL TRACE OSCILLOSCOPE

122A/AR

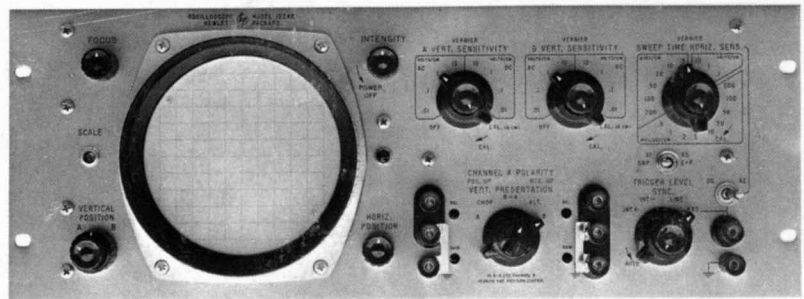

HEWLETT  PACKARD



OPERATING AND SERVICE MANUAL

MODEL 122A/AR
OSCILLOSCOPE

SERIALS PREFIXED: 521- 08210

See Section VII for Instruments with other Serial Prefixes.

Copyright HEWLETT-PACKARD COMPANY/COLORADO SPRINGS DIVISION 1966
1900 GARDEN OF THE GODS ROAD, COLORADO SPRINGS, COLORADO, U. S. A.

TABLE OF CONTENTS

Section	Page	Section	Page
I GENERAL INFORMATION	1-1	V MAINTENANCE	5-1
1-1. Description	1-1	5-1. Introduction	5-1
1-4. Cathode-Ray Tube	1-1	5-3. Test Equipment	5-1
1-7. Cathode-Ray Tube Warranty	1-2	5-5. Performance Check	5-1
1-9. Accessory Available	1-2	5-7. Vertical Amplifier	5-1
1-11. Manual Identification	1-2	5-14. Horizontal Amplifier	5-2
1-13. Scope of Manual	1-2	5-17. Sweep Generator	5-2
II INSTALLATION	2-1	5-21. Adjustments	5-4
2-1. Initial Inspection	2-1	5-24. Turn On Procedure	5-4
2-4. Claims and Repackaging	2-1	5-26. Trigger Generator	5-5
2-7. Preparation for Use	2-1	5-30. Vertical Amplifiers	5-5
2-8. Power Requirements	2-1	5-38. Horizontal Amplifier	5-6
2-10. 230-Volt Operation	2-1	5-44. Sweep Generator	5-7
2-12. Three-Conductor Power Cable	2-1	VI REPLACEABLE PARTS	6-1
2-14. Ventilation Requirements	2-1	6-1. Introduction	6-1
2-16. Installation of Amber Filter	2-1	6-4. Ordering Information	6-1
III OPERATION	3-1	VII MANUAL CHANGES AND OPTIONS	7-1
3-1. Introduction	3-1	7-1. Manual Changes	7-1
3-3. Controls and Connectors	3-1	7-3. Older Instruments	7-1
3-17. Rear Panel Connectors	3-1	7-5. Newer Instruments	7-2
IV PRINCIPLES OF OPERATION	4-1	7-7. Options	7-2
4-1. Over-All Description	4-1	7-9. Option 05	7-2
4-2. General Content	4-1	7-11. Option 06	7-2
4-4. Vertical Amplification Channels	4-1	7-13. Special Instruments	7-2
4-6. Vertical Presentation Switch	4-2	VIII SCHEMATIC DIAGRAMS	8-1
4-8. Horizontal Amplification Switch	4-2	8-1. Schematic Diagrams	8-1
4-11. Sweep Generator	4-2	8-2. General Notes	8-1
4-16. High Voltage Power Supply	4-3	8-4. Voltage and Resistance Diagram Notes	8-1
4-18. Low Voltage Power Supply	4-3	8-5. Removing the Chassis	8-1
		8-7. Tube Replacement	8-1

LIST OF ILLUSTRATIONS

Number	Title	Page	Number	Title	Page
1-1.	Model 122A/AR Oscilloscope	1-0	4-1.	Over-all Block Diagram	4-1
3-1.	Controls and Connectors	3-2	5-1.	Left-Side Adjustment Location Diagram . .	5-4
3-2.	Unbalanced Input	3-3	5-2.	Right-Side Adjustment Location Diagram .	5-6
3-3.	Difference Input	3-4	7-1.	Option 05 Graticule Lighting Schematic . .	7-2
3-4.	Balanced Input	3-5	8-1.	Top View Adjustment Location and Voltage Resistance Diagram	8-2
3-5.	Internal Sweep -- Internal Synchronization .	3-6	8-2.	Bottom View Adjustment Location and Voltage Resistance Diagram	8-3
3-6.	Chopped Operation	3-7	8-3.	Vertical Amplifier	8-4
3-7.	Alternate Sweep Operation	3-8	8-4.	Vertical Amplifier Switch Detail	8-5
3-8.	Internal Sweep -- External Synchronization .	3-9	8-5.	Horizontal Amplifier	8-6
3-9.	Vertical Balance Adjustment	3-10	8-6.	Sweep Generator	8-7
3-10.	Vertical Sensitivity Calibration	3-11	8-7.	Sweep Time - Horiz Sens Switch	8-8
3-11.	Internal Sweep Magnification	3-12	8-8.	High Voltage Power Supply	8-9
3-12.	External Horizontal Input	3-13	8-9.	Low Voltage and Filament Supplies . . .	8-10
3-13.	Intensity Modulation Operation	3-14			
3-14.	Connection to Deflection Plates	3-15			
3-15.	Connecting External Capacitors to Extend Sweep Time	3-16			

LIST OF TABLES

Number	Title	Page	Number	Title	Page
1-1.	Specifications	1-0	5-3.	Horizontal Deflection Sensitivity	5-2
2-1.	Shipping Carton Test Strengths	2-1	5-4.	Sweep Time Accuracy	5-3
3-1.	Common Signal Limits	3-1	5-5.	Low Voltage Power Supply Tolerances . . .	5-4
5-1.	Required Test Equipment	5-0	6-1.	Reference Designators and Abbreviations .	6-1
5-2.	Vertical Deflection Sensitivity	5-1	6-2.	Replaceable Parts	6-2
			7-1.	Manual Changes	7-1

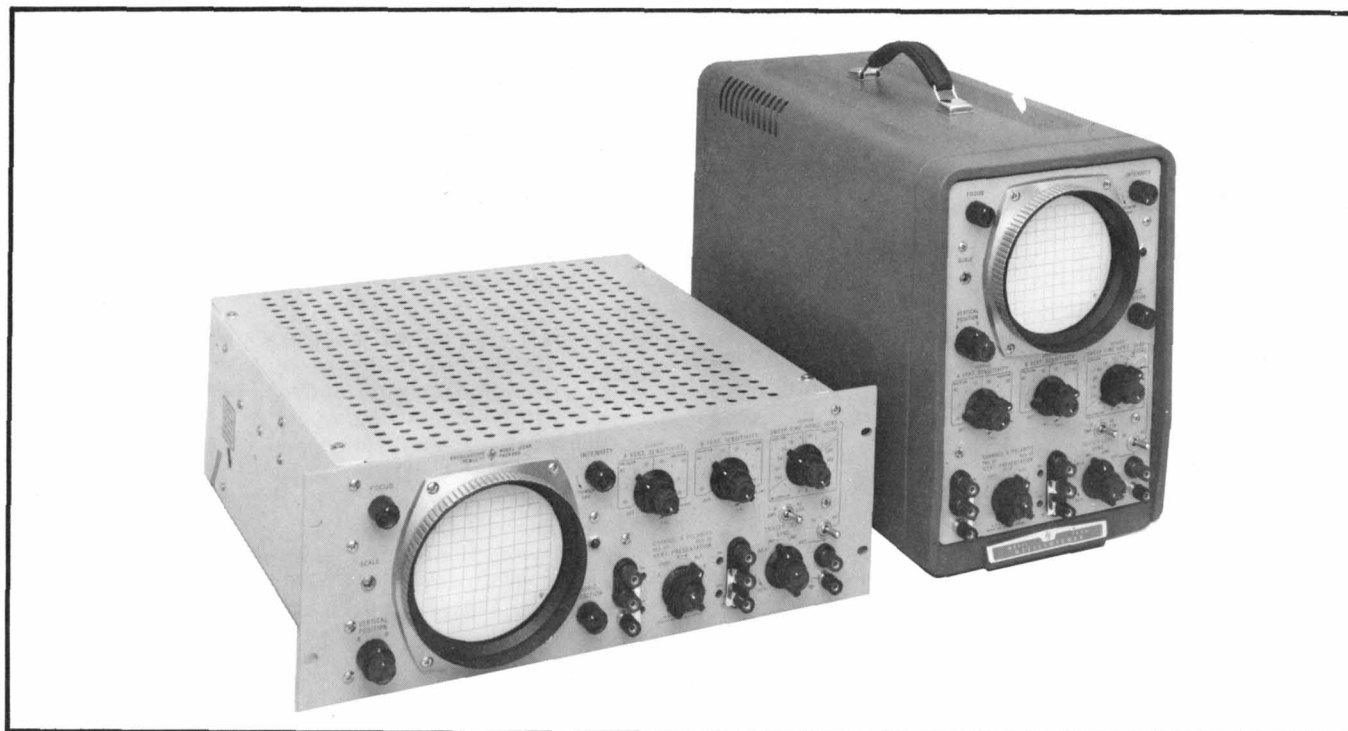

Figure 1-1. Model 122A/AR Oscilloscope

Table 1-1. Specifications

SWEEP

Sweep Range: 15 calibrated sweeps, from 5 $\mu\text{sec}/\text{cm}$ to 200 msec/cm , accurate to within 5%, in a 1, 2, 5 sequence. Vernier permits continuous adjustment of sweep time between calibrated steps and extends the 200 msec/cm range to at least 0.5 sec/cm .

Sweep Expand: X5 sweep expansion may be used on all ranges and expands fastest sweep to 1 $\mu\text{sec}/\text{cm}$. Expansion is about the center of the CRT and expanded sweep accuracy is $\pm 10\%$.

Synchronization: Automatic from 50 Hz to 250 kHz; internally from vertical deflection signals causing 1/2 cm or more vertical deflection; from external signals 2.5 volts peak-to-peak or greater, and from line voltage.

Trigger Point: Control overrides automatic and permits the trigger point to be set between -10 and +10 volts. Turning fully counterclockwise into AUTO restores automatic operation. Positive or negative slope may be selected on the INTERNAL trigger. Triggering in EXTERNAL is automatically established on the negative slope.

VERTICAL AMPLIFIERS

Bandwidth: DC coupled: DC to 200 kHz. AC coupled: 2 Hz to 200 kHz. Bandwidth is independent of calibrated sensitivity setting.

Sensitivity: 10 mv/cm to 100 v/cm . 4 calibrated steps accurate within $\pm 3\%$, 10 mv/cm , 100 mv/cm , 1 v/cm , and 10 v/cm . Vernier permits continuous adjustment of sensitivity between steps and extends 10 v/cm step to at least 100 v/cm .

Internal Calibrator: Calibrating signal automatically connected to vertical amplifier for standardizing of gain, accuracy $\pm 2\%$.

Input Impedance: 1 megohm, approximately 50 pf shunt capacitance.

Phase Shift: Vertical and horizontal amplifiers have same phase characteristics within $\pm 2^\circ$ to 100 kHz when verniers are fully clockwise.

Isolation: Greater than 80 db isolation between channels A and B from dc to 200 kHz.

Balanced Input: On 10 mv/cm range on both amplifiers. Input impedance, 2 megohms shunted by approximately 25 pf. Common mode rejection is at least 40 db. Common mode signal must not exceed ± 3 volts peak.

Difference Input: Both input signals may be switched to one channel to give differential input on all vertical sensitivity ranges. The sensitivity switches may be set separately to allow mixing signals of different levels. Common mode rejection is at least 40 db with both switches on most sensitive ranges; 30 db on other ranges.

Vertical Presentation: Switch selects: A ONLY, B ONLY, B-A, ALTERNATE or CHOPPED.

HORIZONTAL AMPLIFIER

Bandwidth: DC coupled: DC to 200 kHz. AC coupled: 2 Hz to 200 kHz. Bandwidth is independent of calibrated sensitivity setting.

Sensitivity: 0.1 v/cm to 100 v/cm . 3 calibrated steps, accurate within $\pm 5\%$, 0.1 v/cm , 1 v/cm , and 10 v/cm . Vernier permits continuous adjustment of sensitivity between steps and extends 10 v/cm step to at least 100 v/cm .

Input Impedance: Approximately 1 megohm shunted by 100 pf.

Phase Shift: Horizontal and vertical amplifiers have same phase characteristics within $\pm 2^\circ$ to 100 kHz.

SECTION I GENERAL INFORMATION

1-1. DESCRIPTION.

1-2. The Hewlett-Packard Model 122A/AR (Figure 1-1) is a dc to 200 kHz (kilocycle) dual-trace cathode-ray oscilloscope. It has accurately calibrated input sensitivity and sweep speed ranges. This oscilloscope features dc-coupled differential amplifiers and dual trace operation. Differential amplifiers are useful since they reject the common mode (in-phase) part of the input while amplifying the differential (out-of-phase) part. For instance, they will reject hum pick up while amplifying the desired signal. In addition, using differential amplifiers has other advantages. Normally dc amplifiers are difficult to keep stable. Changes such as aging and changes of potentials cause this drift. However, these changes are of the common mode type and are rejected by differential amplifiers. Thus differential amplifiers are also used as stabilized dc amplifiers.

1-3. Dual trace operation is obtained with an electronic switch. This permits observation of two signals at the same time. The two signals may be viewed either alternately during consecutive sweeps or chopped on each sweep. Chopped operation involves switching rapidly between the two signals so that both appear

to be traced simultaneously. The most useful type of presentation in each case will depend upon the frequencies involved. Generally, chopped operation is used with low frequency signals. These signals may also be viewed separately or with their difference (B-A) displayed on the screen. Complete specifications for the Model 122A/AR are given in Table 1-1.

1-4. CATHODE-RAY TUBE.

1-5. The Model 122A/AR uses an internal graticule CRT which eliminates parallax error in observing the display. The CRT is equipped with a nonglare safety face plate.

1-6. A type P31 aluminized phosphor CRT is normally furnished with the Model 122A/AR, however, P2 phosphor (general purpose), P7 phosphor (long persistence) with amber filter, and P11 (fast writing rate) are also available at no extra cost. An external graticule which is edge-lighted with controlled illumination is available under Option 05 (see Table 1-1, Specifications).

Table 1-1. Specifications (Cont'd)

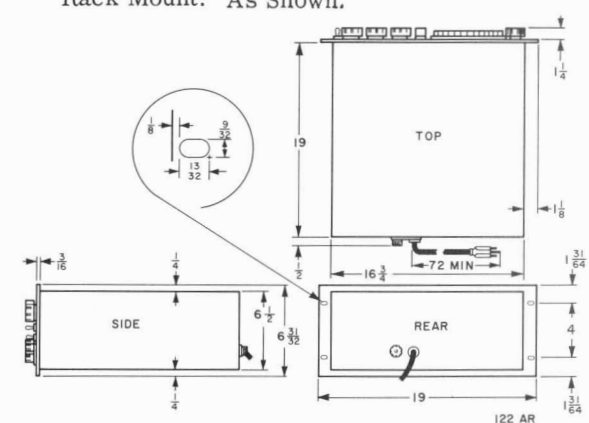
<p>GENERAL</p> <p>Cathode Ray Tube: 5AQP31 mono-accelerator, normally furnished. Other phosphors available, see Modifications. Accelerating potential 3000 volts.</p> <p>Internal Graticule (standard): 10 cm x 10 cm, marked in cm squares with axes in 2 mm subdivisions. Eliminates parallax error.</p> <p>External Graticule (see Modifications): Edge-lighted with controlled illumination, 10 cm x 10 cm marked in cm squares. Major horizontal and vertical axes have 2 mm subdivisions. Color of filter compatible with CRT phosphor supplied: Green with P31 and P2, Amber with P7, Blue with P11.</p> <p>CRT Bezel: Light-proof bezel provides firm mount for oscilloscope camera.</p> <p>CRT Plates: Direct connection to deflection plates via terminals on rear. Sensitivity approximately 20 v/cm.</p> <p>Intensity Modulation: Terminals on rear. +20 v pulse will blank trace of normal intensity.</p> <p>Weight:</p> <p style="padding-left: 20px;">Cabinet Mount: Net, 35 lbs (15, 8 kg). Shipping, 45 lbs (20, 3 kg).</p> <p style="padding-left: 20px;">Rack Mount: Net, 34 lbs (11, 3 kg). Shipping, 49 lbs (22 kg).</p> <p>Power: 115 or 230 volts $\pm 10\%$, 50 to 1000 Hz; approximately 150 watts.</p> <p>Dimensions:</p> <p style="padding-left: 20px;">Cabinet Mount: 9-3/4 in. (248 mm) wide, 15 in. (310 mm) high, 21-1/4 in. (540 mm) deep.</p>	<p style="text-align: center;">Rack Mount: As Shown.</p>  <p>Modifications:</p> <p>CRT Phosphors: (Specify by phosphor number) P31 Standard. P2, P7 with amber filter, P11 available, no charge.</p> <p>Options: (Specify by option number.)</p> <p style="padding-left: 20px;">05: External graticule with P31 phosphor (specify P2, P7, or P11 if required).</p> <p style="padding-left: 20px;">06: Rear terminals in parallel with front terminals. Three 3-pin A/N connectors for vertical inputs and horizontal/external trigger input. (Mating A/N connectors included.)</p> <p>Special order: For single sweep operation specify H15-122A (cabinet) or H15-122AR (rack mount).</p>
--	---

1-7. CATHODE-RAY TUBE WARRANTY.

1-8. The CRT used in the Model 122A/AR is covered by a warranty separate from the instrument warranty. The CRT warranty is included at the back of the manual for your use in the event of CRT failure during the warranty period listed therein.

1-9. ACCESSORY AVAILABLE.

1-10. A Model 10175B Viewing Hood is available at extra cost. This is a face-fitting molded rubber hood used to shade the face of the CRT under high ambient light conditions. It will permit the use of lower beam intensity setting.

1-11. MANUAL IDENTIFICATION.

1-12. Information in this manual applies directly to Model 122A/AR instruments with serial prefix of 521-. The serial prefix is the first 3 digits of the eight digit

serial number (000-00000) used to identify each Hewlett-Packard instrument. If the serial prefix of a Model 122A/AR is not 521-, a change sheet supplied with the manual, or Appendix I will define the difference between that Model 122A or 122AR and the one described in this manual, or a different manual may provide the information. Corrections to this manual due to any errors which existed when this manual was printed, are called Errata and appear only on the change sheet supplied. For information pertaining to change sheets, contact the nearest Hewlett-Packard Sales/Service Office.

1-13. SCOPE OF MANUAL.

1-14. This manual supplies operating and maintenance instructions for the Model 122A/AR Oscilloscopes. Directions are given for the Cabinet Model 122A, but are the same for the Rack Model 122AR. The locations of the controls on the front panel are different, but their functions are the same.

SECTION II INSTALLATION

2-1. INITIAL INSPECTION.

2-2. **MECHANICAL CHECK.** If external damage to the shipping carton is evident, ask the carrier's agent to be present when the instrument is unpacked. Check the instrument for external damage such as broken controls or connectors, and dents or scratches on the panel surface. If damage is evident, see Paragraph 2-4 for recommended claim procedure and repackaging information. If the shipping carton is not damaged, check the cushioning material and note any signs of severe stress as an indication of rough handling in transit. If the instrument appears undamaged, perform the electrical check.

2-3. **ELECTRICAL CHECK.** Check the electrical performance of the Model 122A/AR as soon as possible after receipt. Paragraphs 5-7 through 5-20 contain the performance check procedures which will verify instrument operation within the specifications listed in Table 1-1. This check is also suitable for incoming quality control inspection. If the Model 122A/AR does not perform within the specifications when received, refer to Paragraph 2-4 for recommended claim procedure and repackaging information.

2-4. CLAIMS AND REPACKAGING.

2-5. If physical damage is evident, or if the instrument does not meet specifications when received, notify the carrier and the nearest Hewlett-Packard Sales/Service Office (see list at rear of manual). The Sales/Service Office will arrange for repair or replacement without waiting for settlement of a claim with the carrier.

2-6. The original shipping carton and packaging material, with the exception of accordion-pleated pads, should be used for reshipment. The accordion-pleated pads are fatigued with one use and are not reusable. The Hewlett-Packard Sales/Service Office will also provide information and recommendations on materials to be used if the original packaging material is not available or is not reusable. Materials used should include:

- a. A double-walled carton, see Table 2-1 for test strength required.

Table 2-1. Shipping Carton Test Strengths

Gross Weight (lbs)	Carton Strength (test lbs)
up to 10	200
10 to 30	275
30 to 120	350
120 to 140	500
140 to 160	600

- b. Heavy paper or sheets of cardboard to protect all instrument surfaces; use a nonabrasive material such as polyurethane or cushioned paper such as Kim-pak around all projecting parts.

- c. At least 4 inches of tightly-packed, industry approved shock-absorbing material such as extra firm polyurethane foam.

- d. Heavy-duty shipping tape for securing outside of carton.

2-7. PREPARATION FOR USE.

2-8. POWER REQUIREMENTS.

2-9. The Model 122A/AR Oscilloscope requires a power source of either 115 or 230 volts ac, $\pm 10\%$, single phase, 50 to 1000 Hz, which can deliver approximately 150 watts.

2-10. 230-VOLT OPERATION.

2-11. If the instrument is to be operated from a 230-volt source, the power transformer dual primary windings must be reconnected as follows: Remove the instrument from its case by removing the two large screws from the rear. (Model 122AR requires removal of four screws from the bottom.) Locate the power transformer primary terminals. The two outer pairs of terminals (1 & 2) and (3 & 4) are jumpered together, connecting the windings in parallel. Remove these two jumpers. Connect an insulated jumper between terminals 2 and 3, which connects the two windings in series. Refer to the Low-Voltage Power Supply schematic for details. Replace the 2.0 amp slow-blow fuse with a 1.0 amp slow-blow fuse.

2-12. THREE-CONDUCTOR POWER CABLE.

2-13. For the protection of operating personnel, the National Electrical Manufacturers' Association (NEMA) recommends that the instrument panel and cabinet be grounded. The Model 122A/AR is equipped with a three-conductor power cable which, when plugged into an appropriate receptacle, grounds the instrument. The offset (round) pin on the power cable connector is the ground pin. To preserve the protection feature when operating the Model 122A/AR from a two-contact outlet, use a three-conductor to two-conductor adapter and connect the green lead on the adapter to ground at the power outlet.

2-14. VENTILATION REQUIREMENTS.

2-15. The Model 122A (cabinet mount) and Model 122AR (rack mount) instruments are provided with adequate ventilation openings for circulation of cooling air. When operating, the instrument should be located with at least 3 inches of clearance around the top, bottom, and rear of the housing.

2-16. INSTALLATION OF AMBER FILTER.

2-17. An amber filter (hp Part No. 120A-83A) is supplied with oscilloscopes having a CRT with type P7 phosphor. This filter may be installed for improved visual observation of displays such as single-shot phenomena or very low frequency applications. The filter will improve the long persistency characteristics

desired for visual observance of this type display. To install the filter, proceed as follows:

- a. Remove front panel CRT bezel.
- b. Set filter into bezel, aligning larger rectangular slots in the edge of filter with guide metal posts of the bezel casting.
- c. Remove oscilloscope top cover or case for access to rear of CRT.
- d. Loosen clamp at socket of CRT.
- e. Carefully push CRT toward rear of instrument enough to provide clearance for thickness of installed filter (about 1/8 inch).
- f. Replace bezel with filter and tighten bezel screws.
- g. Slide CRT forward until light mask on front of CRT just lightly touches filter.
- h. Tighten clamp just enough to keep CRT from turning. Do not over-tighten clamp or tube damage may result.
- i. Check alignment of trace with graticule according to procedure in Paragraph 3-9.

SECTION III OPERATION

3-1. INTRODUCTION.

3-2. The Model 122A/AR Oscilloscope provides features of dual trace and 200 kHz bandwidth in both vertical and horizontal amplifiers. All operating controls are located on the front panel in a functional arrangement. The instrument may be used as an ordinary oscilloscope with a single trace, or when you want to compare two quantities it can provide two separate traces, which in many ways is like having two oscilloscopes. Both vertical amplifiers will accept either single-ended or balanced input signals on all ranges of sensitivity.

3-3. CONTROLS AND CONNECTORS.

3-4. FRONT PANEL. Figure 3-1 identifies the front panel controls, connectors and indicators, and provides a short description of their functions. The functions of the controls are discussed more completely in Paragraphs 3-5 through 3-16, below.

3-5. INTENSITY/POWER. Rotate clockwise to turn on the oscilloscope. The pilot lamp should glow, indicating power applied. After approximately 30 seconds of warm-up, the trace or a spot should appear on the screen. Adjust the control for the desired intensity.

3-6. FOCUS. Adjust for optimum trace width in conjunction with setting of INTENSITY.

3-7. HORIZONTAL POSITION. Adjust to shift the trace right or left of the center line of the graticule.

3-8. VERTICAL POSITION. Adjust to position the Channel A and Channel B traces above and/or below the horizontal center line of the graticule.

3-9. SCALE (alignment adjustment). To compensate for external magnetic disturbances and slight manufacturing tolerances, a front panel screwdriver adjustment has been provided to align the trace with the graticule. Adjust SCALE whenever realignment of the trace seems necessary. A check should be made after moving the instrument to a new operating location.

3-10. VERTICAL SENSITIVITY. Set the Channel A and Channel B SENSITIVITY switches to the desired degree of deflection sensitivity, ac or dc input. Adjust the vernier knob to the value desired between the switch settings.

Note

Do not exceed the common signal voltage limit under any circumstances. This limit is ± 3 volts on the input grid. Note that this is the sum of all voltages (dc plus peak ac).

3-11. CHANNEL A POLARITY. Set this switch to the position required for upward deflection of the trace, either positive or negative.

Table 3-1. Common Signal Limits

Attenuator Setting	Common Signal Limit
0.01 volts/cm	± 3 volts
0.1 volts/cm	30 volts
1.0 volts/cm	300 volts
10.0 volts/cm	500 volts

3-12. VERTICAL PRESENTATION. Set this switch to the position required for the type presentation desired. (Figures 3-2 through 3-12 give detailed information for various input modes.)

3-13. SWEEP TIME/HORIZONTAL SENSITIVITY. Set this switch to the desired SWEEP TIME or to the degrees of HORIZONTAL SENSITIVITY desired, if using external sweep source. Adjust the vernier knob to the value desired between switch settings.

3-14. SYNC. Select the source of synchronization by setting the SYNC switch to INTERNAL + or -, or to LINE or to EXTERNAL for the desired display.

3-15. TRIGGER LEVEL. Adjust this control to the desired level of trigger voltage, or rotate it to the extreme counterclockwise position for AUTOMATIC sweep. The toggle switch to the right of the TRIGGER LEVEL/SYNC controls selects either ac or dc coupling for the horizontal input, or when using external sweep source, allows ac coupling only. Horizontal deflection or external sync signals are fed into the terminals immediately below this toggle switch.

3-16. SWEEP EXPAND. This toggle switch enables the user to display normal sweep, or to expand the presentation five times horizontally, depending on switch position, X1 or X5.

3-17. REAR PANEL CONNECTORS.

3-18. Rear panel connections are available for direct input to the Z-axis for intensity modulating the trace. (A negative polarity will brighten the trace.) See Figure 3-13.

3-19. Direct input to the vertical and horizontal deflection plates is available at the rear panel. Either ac or dc coupling may be used. See Figure 3-14.

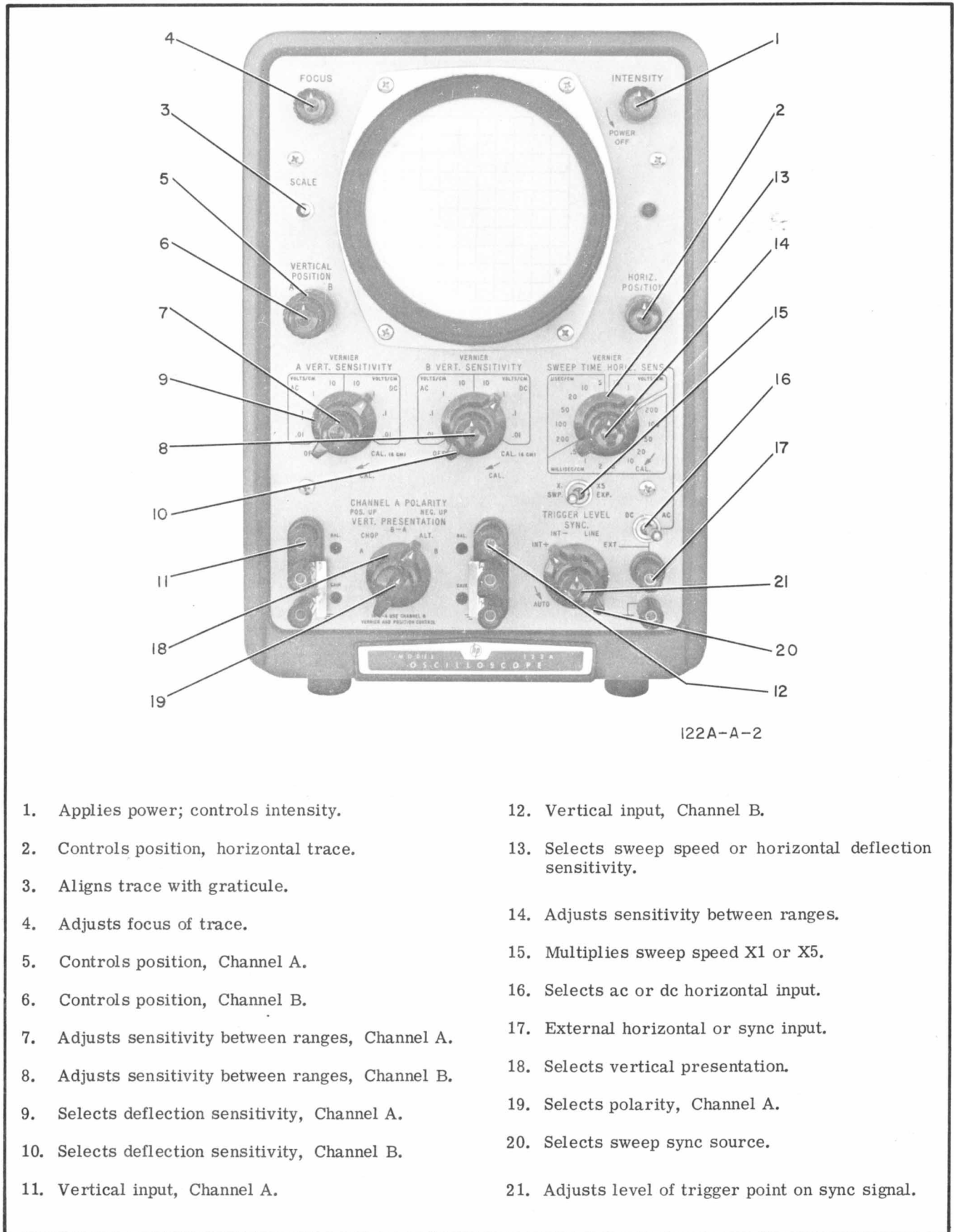

122A-A-2

- | | |
|---|---|
| 1. Applies power; controls intensity. | 12. Vertical input, Channel B. |
| 2. Controls position, horizontal trace. | 13. Selects sweep speed or horizontal deflection sensitivity. |
| 3. Aligns trace with graticule. | 14. Adjusts sensitivity between ranges. |
| 4. Adjusts focus of trace. | 15. Multiplies sweep speed X1 or X5. |
| 5. Controls position, Channel A. | 16. Selects ac or dc horizontal input. |
| 6. Controls position, Channel B. | 17. External horizontal or sync input. |
| 7. Adjusts sensitivity between ranges, Channel A. | 18. Selects vertical presentation. |
| 8. Adjusts sensitivity between ranges, Channel B. | 19. Selects polarity, Channel A. |
| 9. Selects deflection sensitivity, Channel A. | 20. Selects sweep sync source. |
| 10. Selects deflection sensitivity, Channel B. | 21. Adjusts level of trigger point on sync signal. |
| 11. Vertical input, Channel A. | |

Figure 3-1. Controls and Connectors

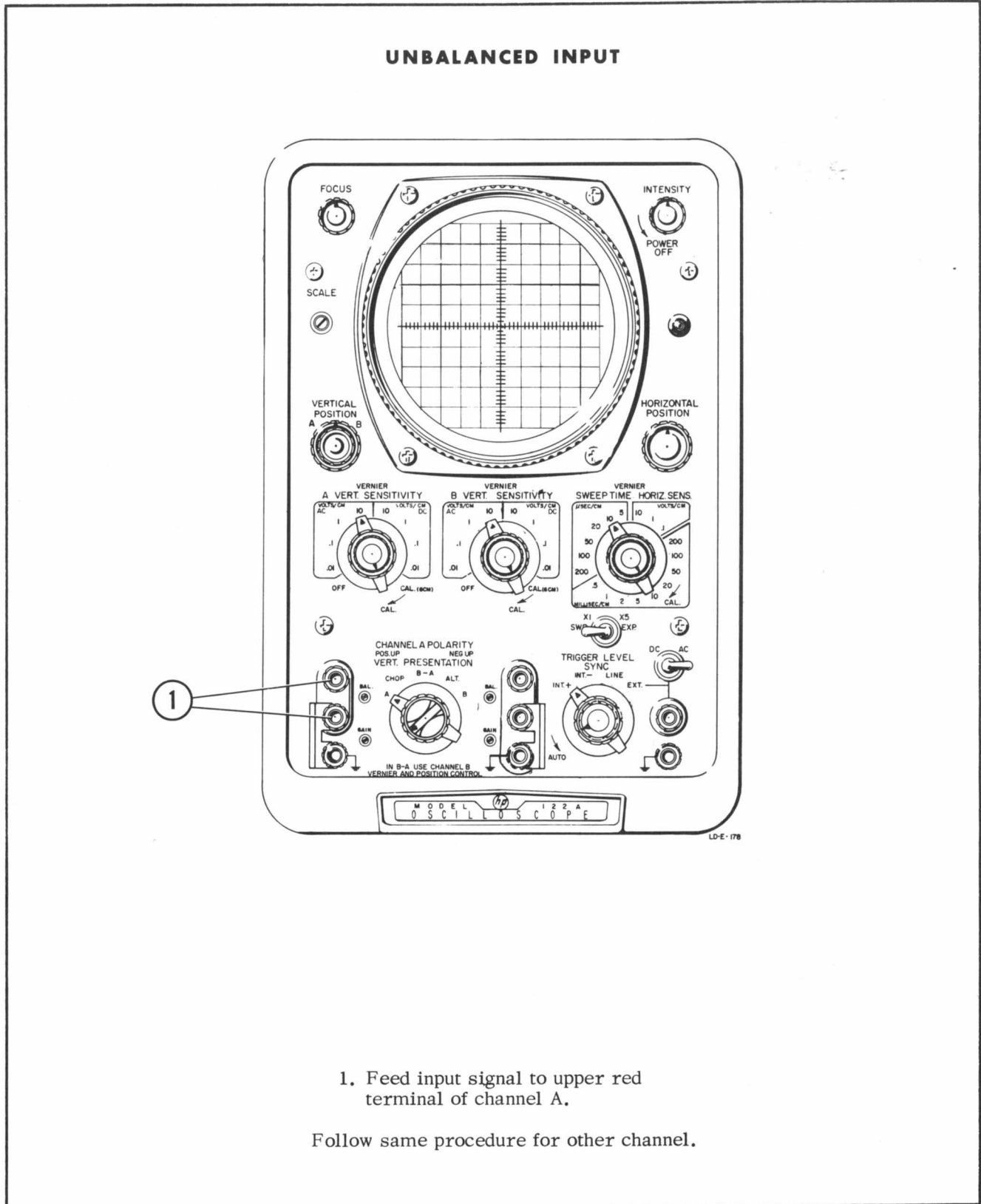
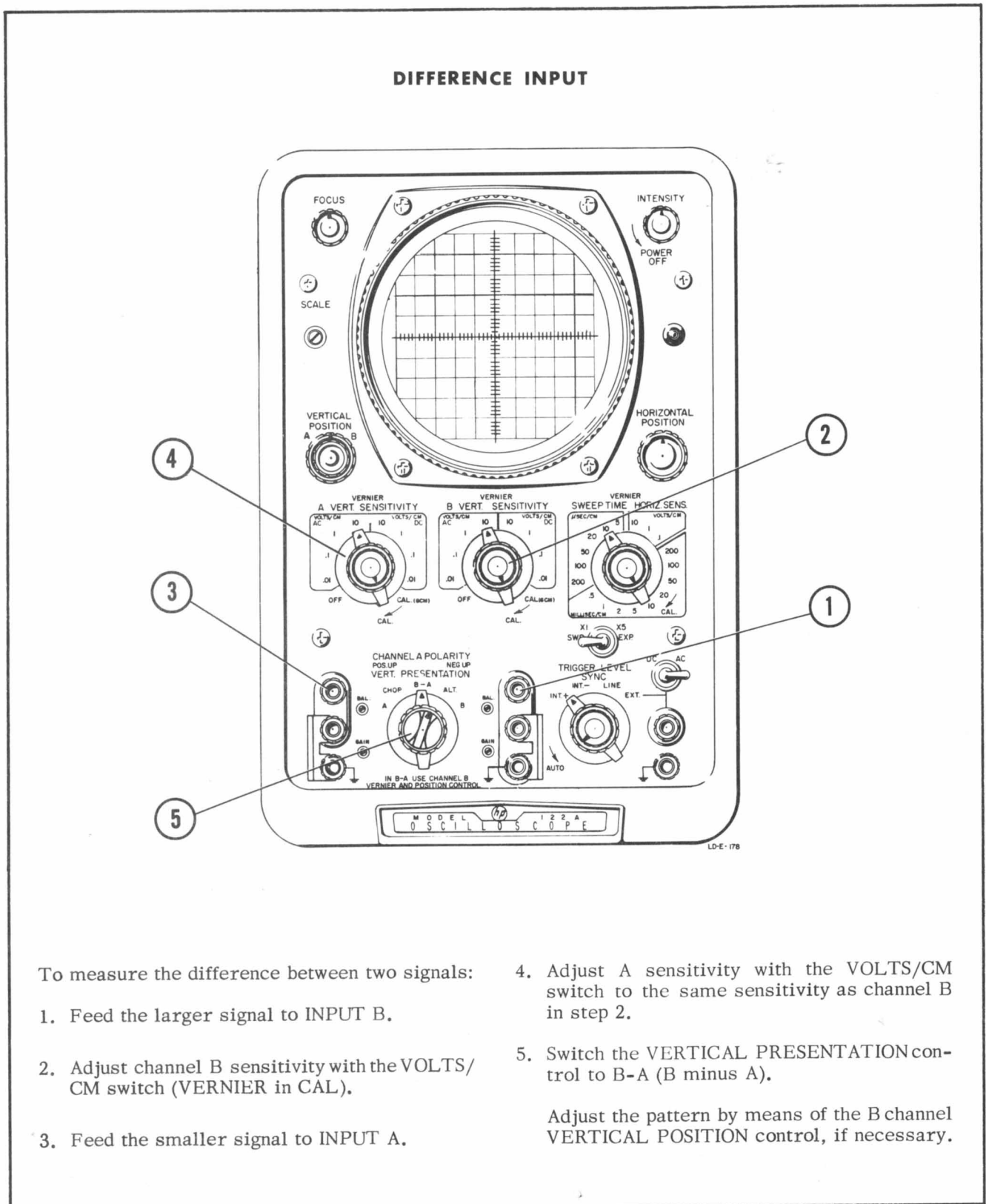

Figure 3-2. Unbalanced Input



To measure the difference between two signals:

1. Feed the larger signal to INPUT B.
2. Adjust channel B sensitivity with the VOLTS/CM switch (VERNIER in CAL).
3. Feed the smaller signal to INPUT A.
4. Adjust A sensitivity with the VOLTS/CM switch to the same sensitivity as channel B in step 2.
5. Switch the VERTICAL PRESENTATION control to B-A (B minus A).

Adjust the pattern by means of the B channel VERTICAL POSITION control, if necessary.

Figure 3-3. Difference Input

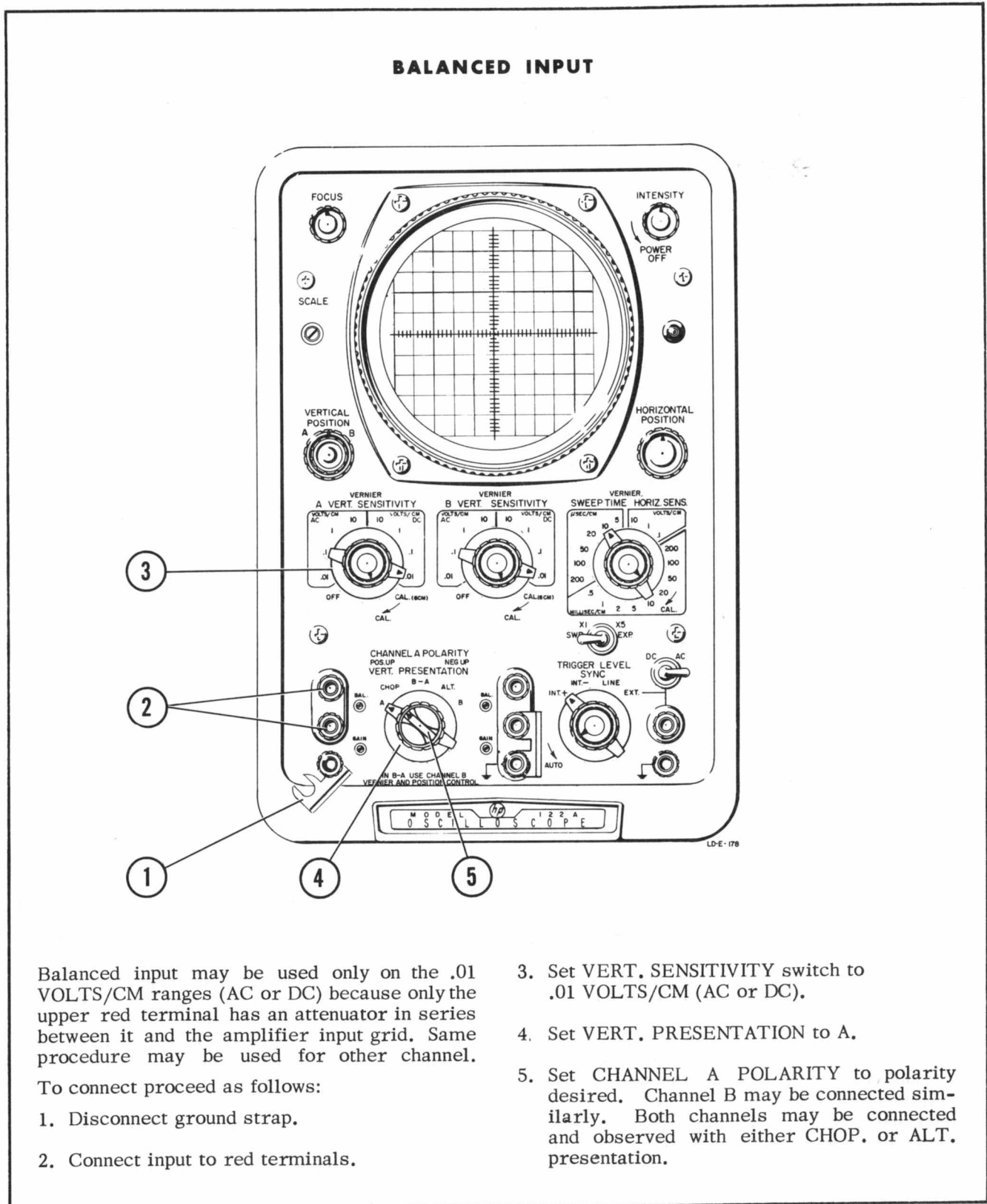

Balanced input may be used only on the .01 VOLTS/CM ranges (AC or DC) because only the upper red terminal has an attenuator in series between it and the amplifier input grid. Same procedure may be used for other channel.

To connect proceed as follows:

1. Disconnect ground strap.
2. Connect input to red terminals.
3. Set VERT. SENSITIVITY switch to .01 VOLTS/CM (AC or DC).
4. Set VERT. PRESENTATION to A.
5. Set CHANNEL A POLARITY to polarity desired. Channel B may be connected similarly. Both channels may be connected and observed with either CHOP. or ALT. presentation.

Figure 3-4. Balanced Input

INTERNAL SWEEP — INTERNAL SYNCHRONIZATION

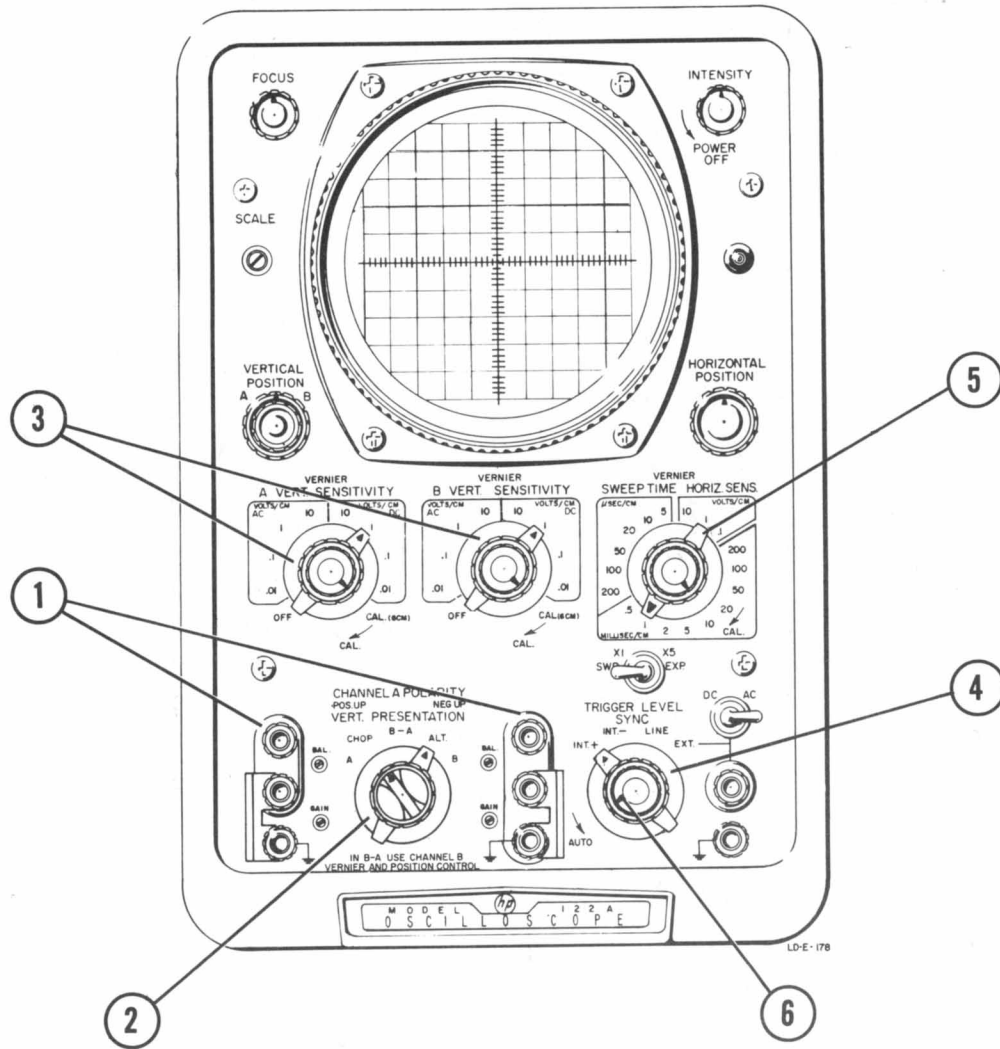

1. Feed vertical input signal(s) into vertical input terminal(s).
2. Set VERT. PRESENTATION switch to desired presentation.
3. Adjust VERT. SENSITIVITY switch(es) for desired sensitivity. (Note that there are both AC and DC coupled ranges.)
4. Set SYNC switch to INT (+ or -), depending upon slope of trigger point desired.
5. Set SWEEP TIME - HOR. SENS. switch for desired sweep speed.
6. If AUTOMATIC sweep is not desired, rotate TRIGGER LEVEL control to select level of trigger point.

Figure 3-5. Internal Sweep -- Internal Synchronization

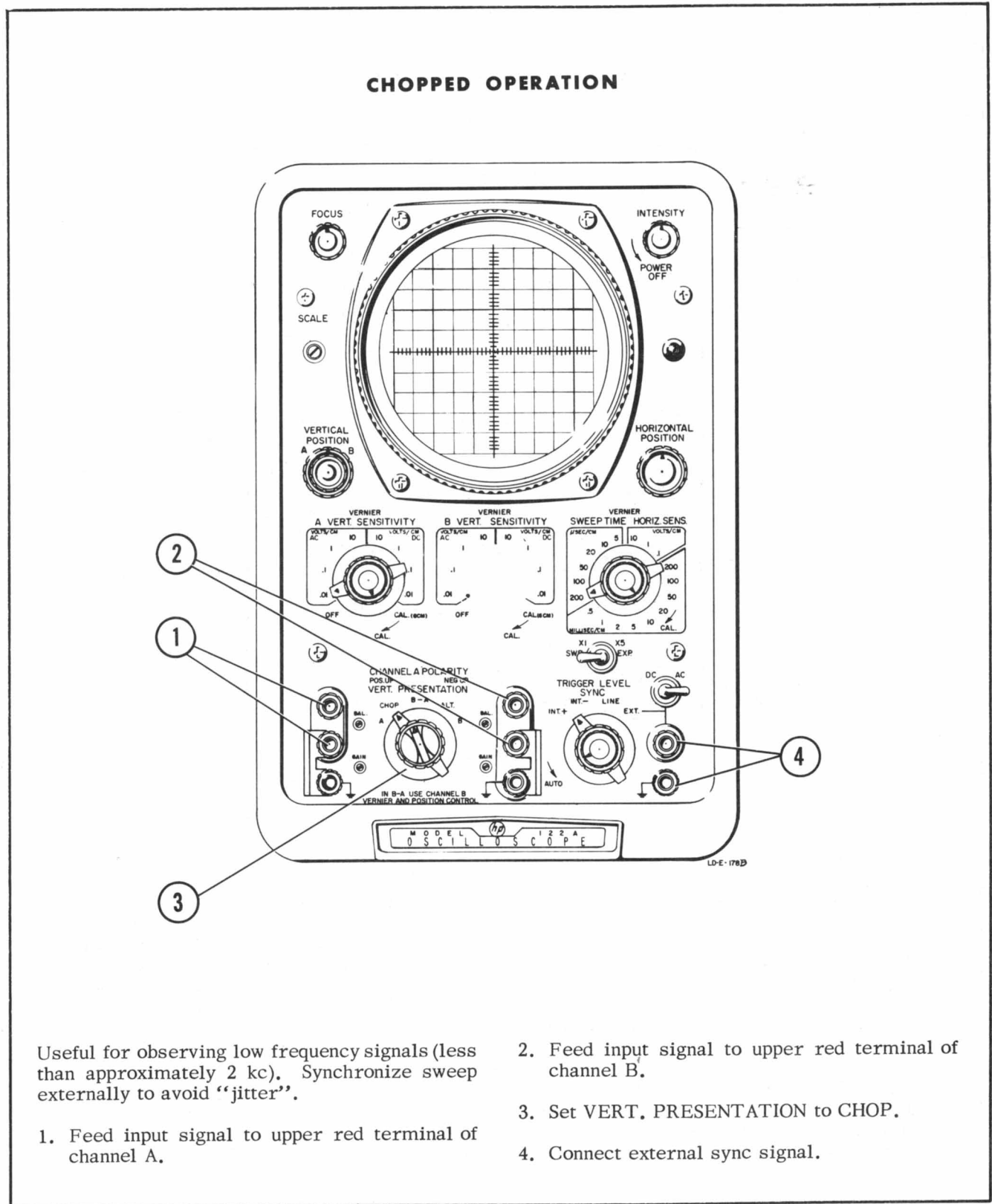
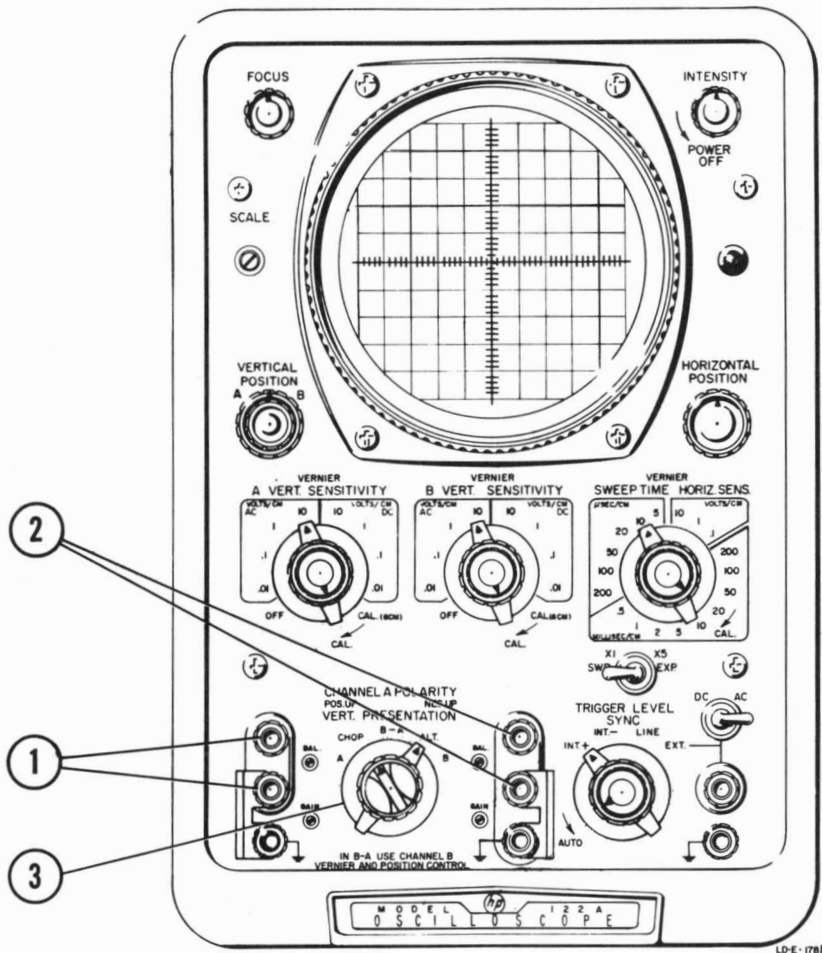

Figure 3-6, Chopped Operation

ALTERNATE SWEEP OPERATION



Useful for observing higher frequency signals (above approximately 2 kc).

1. Feed input signal to upper red terminal of channel A.
2. Feed input signal to upper red terminal of channel B.
3. Set VERT. PRESENTATION to ALT. Use this method of presentation for fast sweep speeds. Since each is individually triggered, this presentation can be used with internal

triggering even when the two signals are not related in frequency. When operating in this manner the intensity of the traces will be reduced if the traces are separated on the screen. This may be eliminated by adjusting the VERTICAL POSITION controls so that the traces overlap. Usually operation will involve signals related in frequency. Also, if it is desired to maintain phase information between the two signals being viewed, it is necessary to use external triggering. If this is the case, use external triggering. It is then possible to separate the traces without intensity reduction.

Figure 3-7. Alternate Sweep Operation

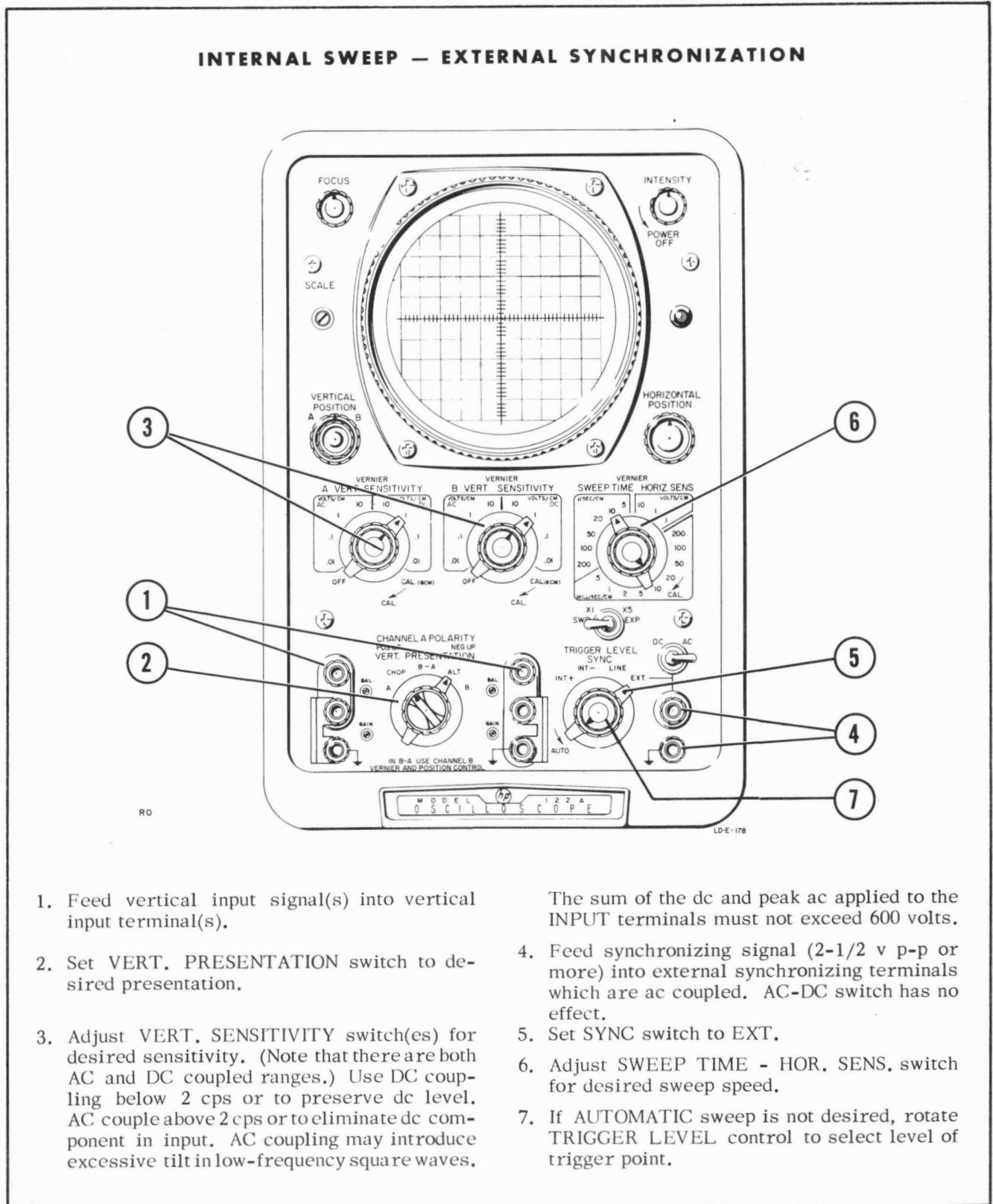
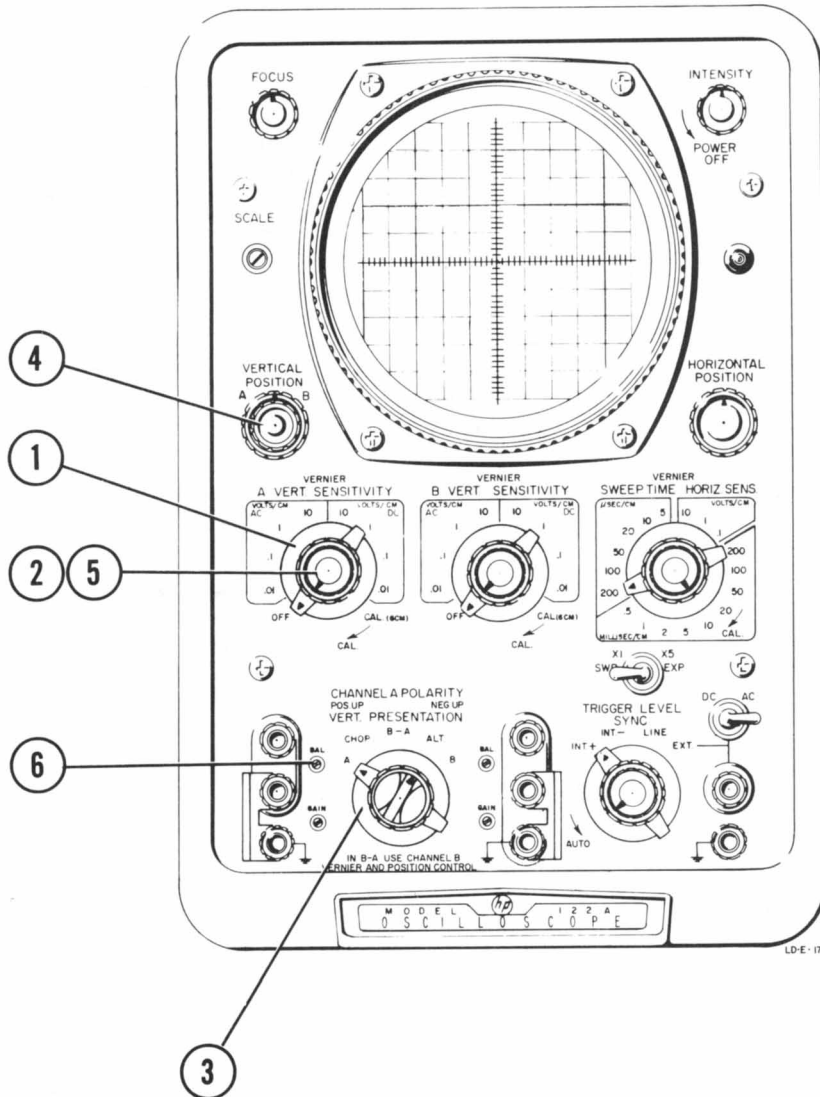

Figure 3-8. Internal Sweep -- External Synchronization

VERTICAL BALANCE ADJUSTMENT



- | | |
|---|--|
| 1. Set both VERT. SENSITIVITY switches to OFF. | 4. Center trace with VERT. POS. control. |
| 2. Turn both VERT. SENSITIVITY VERNIERS fully counterclockwise. | 5. Turn VERNIER fully clockwise. |
| 3. Set VERT. PRESENTATION switch to A. | 6. Adjust BAL control to center trace or spot. Repeat procedure for channel B. |

Figure 3-9. Vertical Balance Adjustment

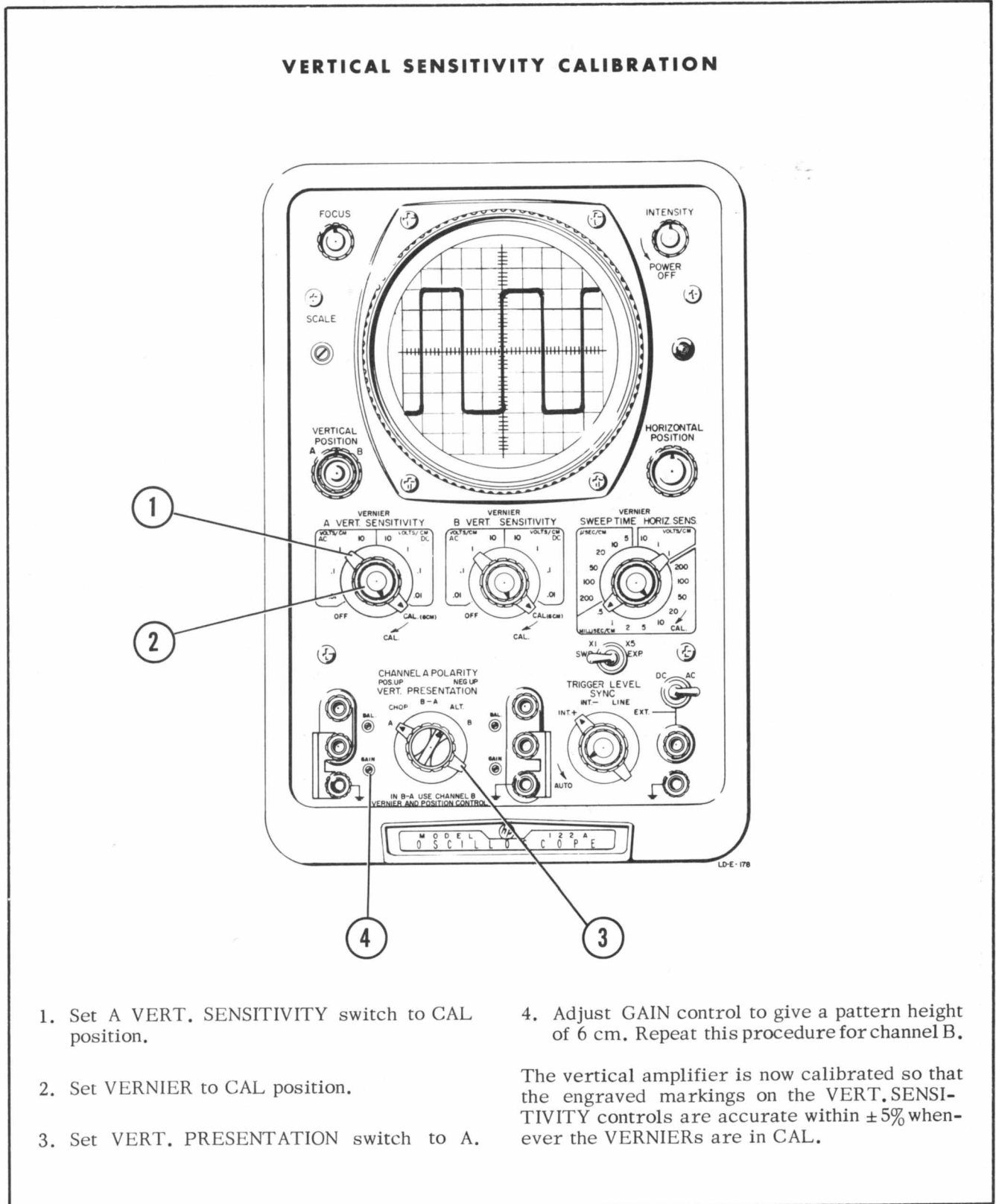
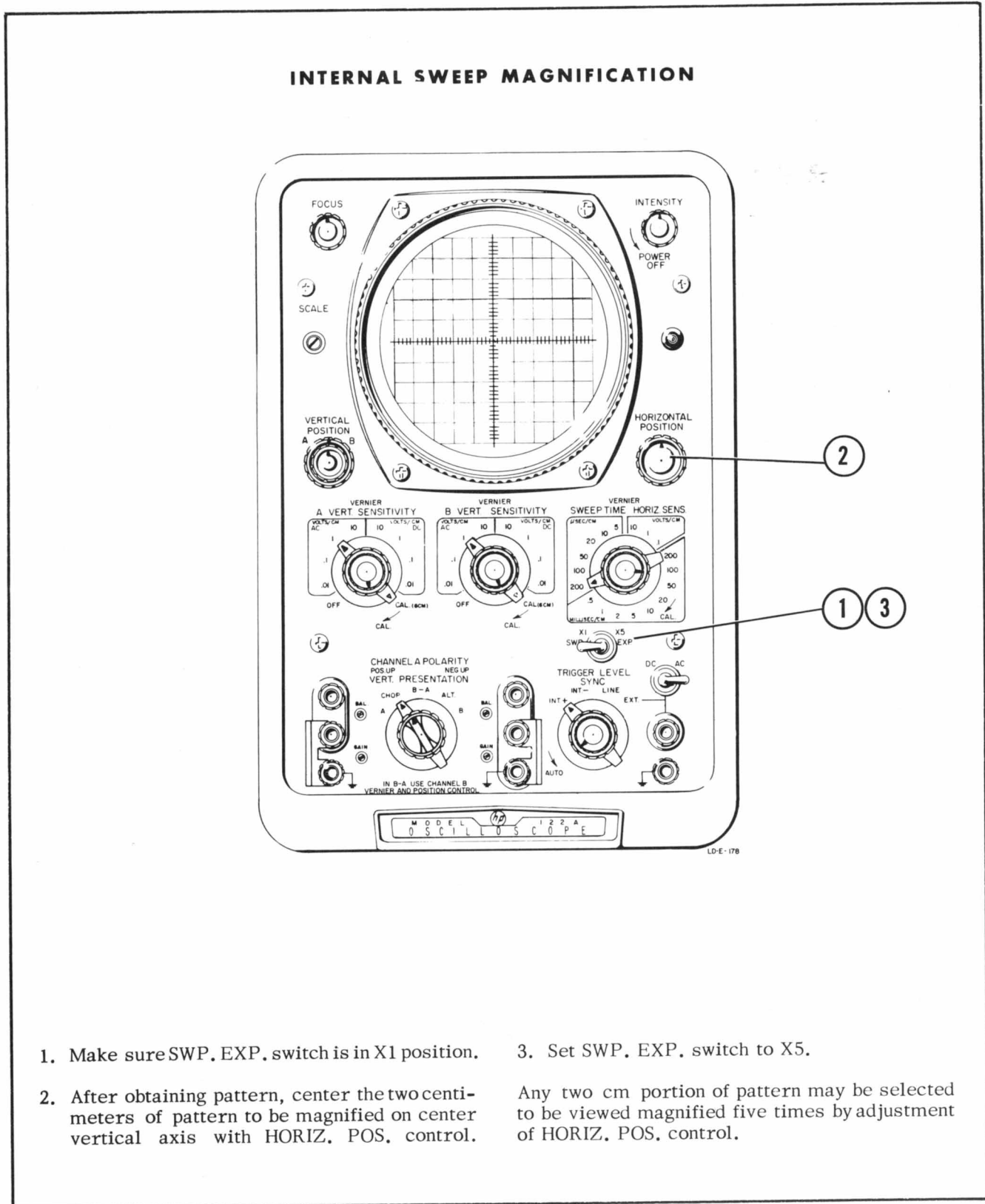

Figure 3-10. Vertical Sensitivity Calibration



1. Make sure SWP. EXP. switch is in X1 position.
2. After obtaining pattern, center the two centimeters of pattern to be magnified on center vertical axis with HORIZ. POS. control.

3. Set SWP. EXP. switch to X5.

Any two cm portion of pattern may be selected to be viewed magnified five times by adjustment of HORIZ. POS. control.

Figure 3-11. Internal Sweep Magnification

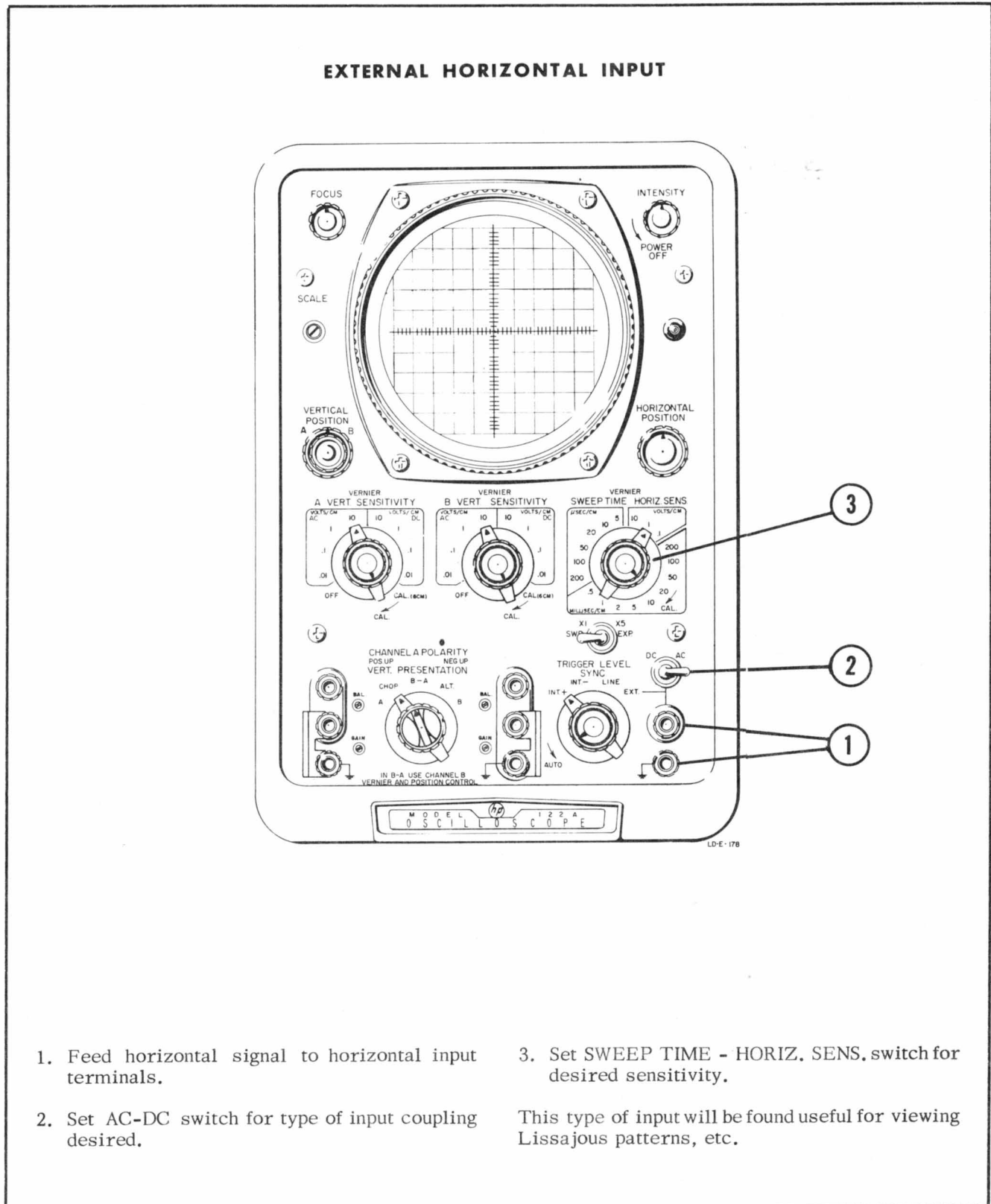
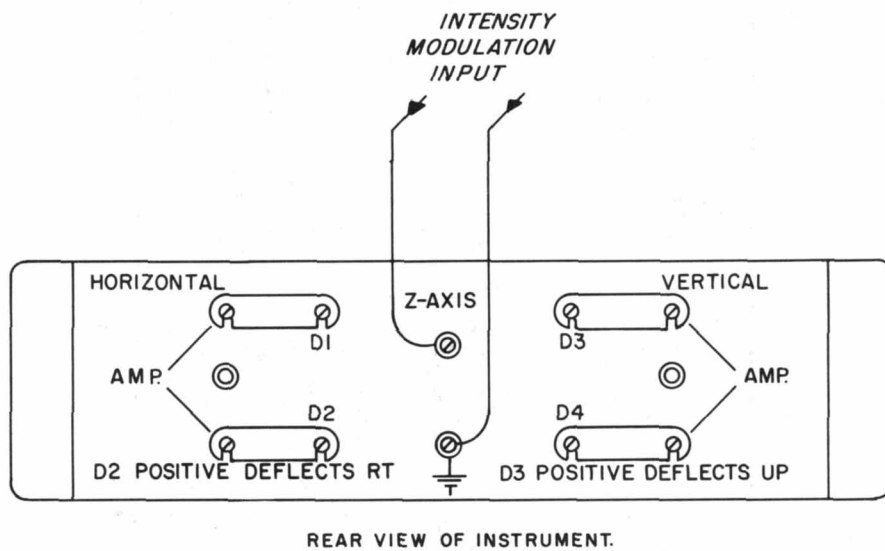

Figure 3-12. External Horizontal Input

INTENSITY MODULATION OPERATION



LD - M - 174

CAUTION - The deflection plates of the oscilloscope operate at a dc potential above ground.

TURN THE INSTRUMENT OFF BEFORE REMOVING THE COVER PLATE FROM THE DEFLECTION PLATE TERMINALS, TO AVOID COMING IN CONTACT WITH HIGH VOLTAGES.

To intensity modulate with an external signal:

1. Remove the vertical jumper marked Z-axis.
2. Connect the external intensity modulation signal to these terminals (a negative signal will brighten the trace).

Figure 3-13. Intensity Modulation Operation

CONNECTION TO DEFLECTION PLATES

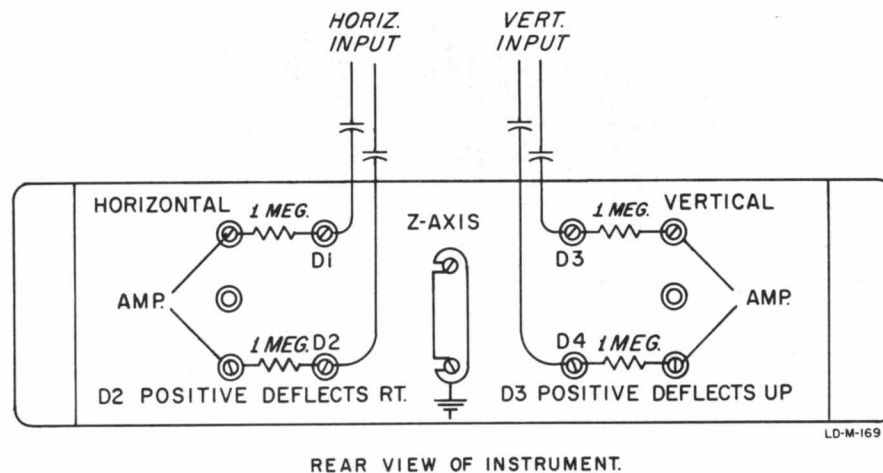

CAUTION: Deflection plates of cathode-ray tube operate at high dc potentials. TURN MODEL 122A OFF BEFORE REMOVING COVER PLATE FROM DEFLECTION PLATE TERMINALS.

To connect an external signal to the deflection plates:

AC COUPLED

1. Remove the jumpers going to terminals D1 and D2 for horizontal input and/or D3 and D4 for vertical input.
2. Connect 1 megohm, 1/2 watt resistors in place of the jumpers removed in step 1.
3. Connect the vertical input blocking capacitors to terminals D3 and D4 and the horizontal blocking capacitors to D1 and D2.

The POSITION controls on the Model 122A will still control the pattern and good focus will be maintained.

DIRECT COUPLED

1. Remove the jumpers going to terminals D1 and D2 for horizontal input and/or D3 and D4 for vertical input.
2. Connect leads from the vertical input directly to D3 and D4 and the lead from the horizontal input directly to D1 and D2.

POSITION controls will no longer control pattern. Position voltages must be furnished by the signal source. Best picture focus is obtained when plates are at +275 volts with respect to Model 122A chassis.

Figure 3-14. Connection to Deflection Plates

CONNECTING EXTERNAL CAPACITORS TO EXTEND SWEEP TIME

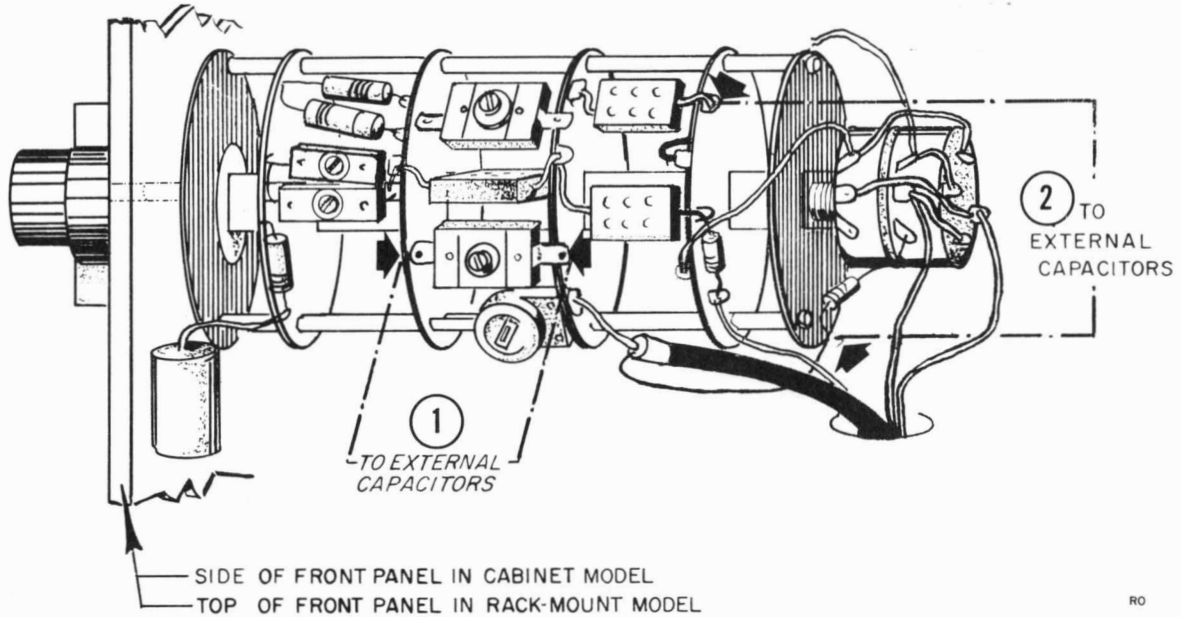

The slowest calibrated sweep provided on the instrument is 1/5 second/cm. This can be extended with the SWEEP TIME VERNIER to at least 1/2 second/cm or 5 seconds for the full 10 cm sweep. If you wish a slower sweep the range can be extended indefinitely by connecting a pair of external capacitors to the sweep circuits.

To extend the sweep time, remove chassis from cabinet.

1. Connect external capacitor across capacitor shown on SWEEP TIME/CM switch.
2. Connect external capacitor from point shown to ground.

Values of both capacitors are the same and will be determined by the sweep speed desired. Note that the only ranges that these capacitors will affect are the 50, 100, and 200 MICROSECONDS/CM ranges. The extension of the sweep time is in proportion to the amount of capacity added to the circuit. Using 2 μ fd capacitors will increase the calibration of the above ranges to approximately 0.5, 1, and 2 seconds/cm respectively.

The capacitor mentioned in step 1 of this figure must be a high-quality type such as mylar. No loss of sweep linearity occurs if a capacitor with these specifications is used. The second capacitor is connected to the hold-off circuits and does not require special characteristics.

Figure 3-15. Connecting External Capacitors to Extend Sweep Time

SECTION IV PRINCIPLES OF OPERATION

4-1. OVER-ALL DESCRIPTION.

4-2. GENERAL CONTENT.

4-3. This section contains a description of the principles of operation of the Model 122A/AR Oscilloscope. The oscilloscope is comprised of five major functional circuit groups: the vertical amplifiers, the sweep generator, the horizontal amplifier, the low-voltage power supply, and the high-voltage power supply (see Figure 4-1).

4-4. VERTICAL AMPLIFICATION CHANNELS.

4-5. Since the two vertical channels are similar, only one description will be given. The vertical amplifier receives the input signal, amplifies it, and drives the vertical deflection plates. It provides attenuation of the input signal, determines the vertical position of the spot on the screen, and supplies a signal for internal synchronization. The signal comes into the input terminals and is fed to the ac-dc section of the VERT SENSITIVITY switch. If the switch is on

an ac range, the signal goes through a capacitor. If the switch is on a dc range, the signal goes directly to the attenuator. The attenuator has three frequency-compensated networks: a straight-through range, an OFF position (where the input grid is shorted), and a CAL position. In the CAL position the calibrator output is connected to the vertical amplifier input and plate voltage is connected to the calibrator. The calibrator is a neon-lamp relaxation oscillator. The vertical amplifier is composed of three dc-coupled differential stages in cascade. Common to the two input channel amplifiers are a switching amplifier, a switching multivibrator and a trigger amplifier. The input stage of each channel has the BAL adjustment between the cathodes. The VERT SENSITIVITY VERNIER and the GAIN adjustment are between the plates of the input amplifier stage. The second and output stages in each channel have plate-to-grid neutralization. The VERTICAL POSITION control is connected between the cathodes of the second stage. The output stage is controlled by the switching amplifier whose plates furnish the cathode

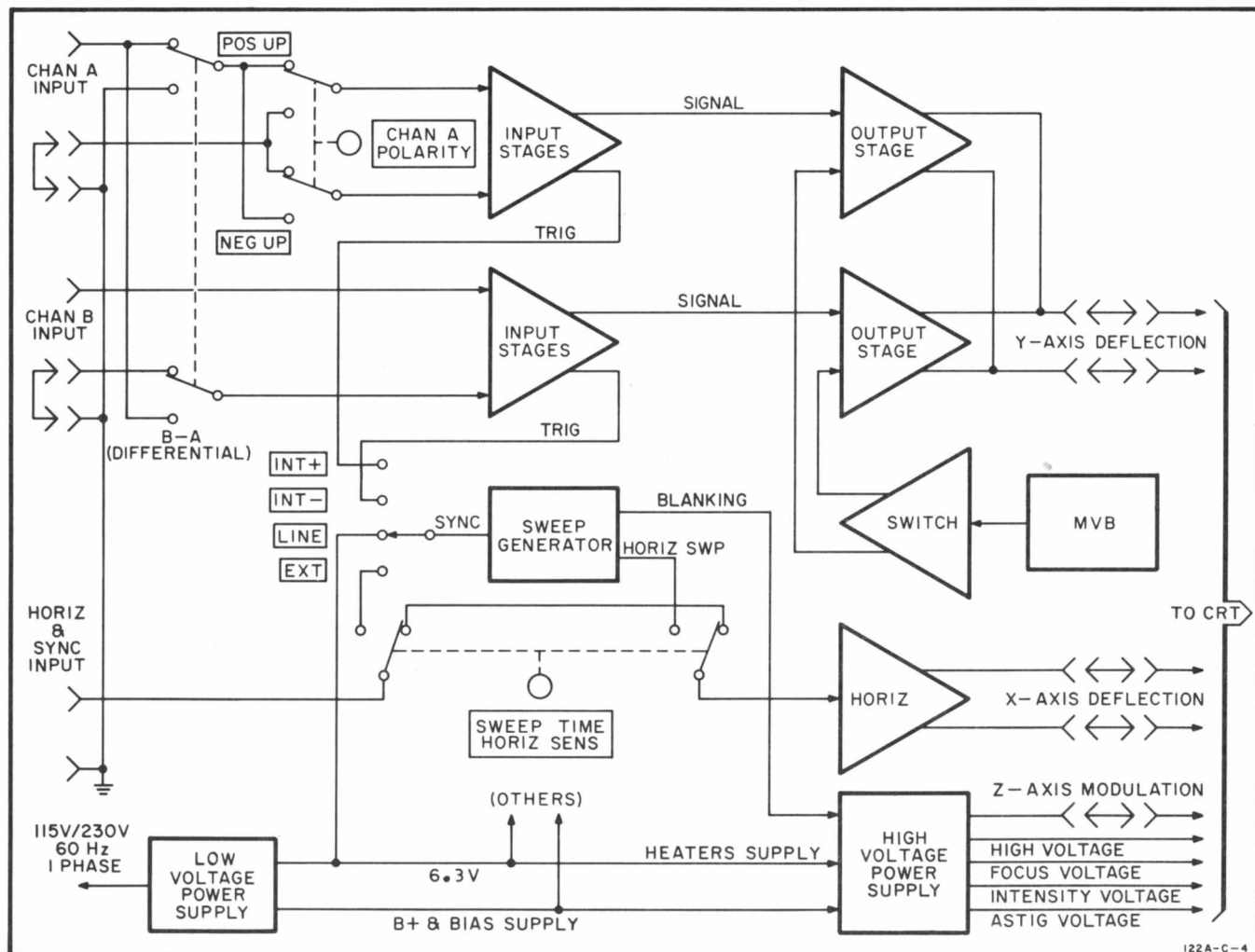

Figure 4-1. Over-all Block Diagram

current for the output stage. The switching amplifier is controlled, in turn, by the switching multivibrator.

4-6. VERTICAL PRESENTATION SWITCH.

4-7. The vertical presentation switch selects the type of vertical amplifier operation as follows:

a. A or B. The locked state is used when the VERT PRESENTATION switch is set to A, B, or B-A. Note that the multivibrator can be locked in either of its two possible states (Channel A on, or Channel B on). The other channel (not used) is biased off. In the B-A position, Channel B is locked on.

b. ALT. The bistable state is used when the VERT PRESENTATION switch is set to ALT. Bistable means stable in either of two positions. For example, when operating in the ALT position, Channel A is off and Channel B is on until a trigger pulse is received from the sweep. At this moment Channel A is turned on and Channel B is turned off. This action is repetitive and occurs at the end of each sweep.

c. CHOP. In the CHOP position the multivibrator is astable. The circuit is a free-running multivibrator with approximately a 40 kHz rate.

d. B-A. In the B-A (B minus A) position the signal from Channel B input is fed directly into the Channel B amplifier. The signal from Channel A input is fed into the opposite side of the Channel B differential amplifier. The output of the Channel B amplifier is then the difference between the Channel B and Channel A signals. This is the only signal shown on the screen.

4-8. HORIZONTAL AMPLIFICATION SWITCH.

4-9. The horizontal amplifier receives an input signal either from the horizontal input terminals or from the internal sweep generator, amplifies the signal, and drives the horizontal deflection plates. The horizontal amplification channel also provides attenuation of the input signal, magnification of the internal sweep and determines the horizontal position of the trace on the screen. The signal comes into the input terminals and is fed to the AC-DC switch. If this switch is in the AC position the signal goes through a capacitor which blocks any dc component. If this switch is in the DC position the signal goes straight through. The horizontal input signal passes through the horizontal sensitivity section of the SWEEP TIME HORIZ SENS switch. This switch has a three-position frequency-compensated attenuator.

4-10. The signal which is fed into the horizontal amplifier may be from either an external source or a sawtooth voltage from the sweep generator. The position of the SWEEP TIME-HORIZ SENS switch will determine which signal is fed into the amplifier. The amplifier consists of two differential stages in cascade. Plate-to-grid neutralization is used in both stages. The input differential amplifier, V101A, is driven single-ended. The grid of the undriven tube, V101B, connects to the POSITION potentiometer to obtain its bias. Two potentiometers, HORIZ SENS VERNIER and Horiz Gain, in the cathode circuit of V101 provide gain adjustment. These potentiometers are in the circuit only when the SWEEP TIME-HORIZ SENS switch is in the HORIZ SENS ranges. In the SWEEP TIME ranges the SWP EXP switch is used.

Either the X1 or the X5 RC networks may be switched into the cathode circuit of V101. A Horiz Bal potentiometer and a Phase Adj capacitor are connected between the plates of V101. Tube V101 feeds another differential amplifier stage, V102. The output of V102 drives the horizontal deflection plates of the CRT.

4-11. SWEEP GENERATOR.

4-12. The sweep generator consists of a trigger generator and a sawtooth generator. The trigger generator receives the synchronizing signal selected by the SYNC selector switch and generates a pulse which initiates the action of the sawtooth generator. The sawtooth generator then produces one complete cycle. It automatically shuts itself off by means of feedback upon completion of one cycle. The sweep circuit will operate again when another pulse is received from the trigger generator, but only after a hold-off time during which all of the circuits have had time to return to their quiescent voltages. This delay is necessary so that successive waveforms will start from the same voltage each time.

4-13. TRIGGER GENERATOR. The trigger generator consists of a synchronizing circuit and a trigger tube, V201. The synchronizing circuit receives a signal either from the vertical amplifier for internal synchronization (+ or -), from an internal 6.3-volt source for line frequency synchronization, or from the horizontal input terminals for external synchronization. The trigger generator converts the signal into a fast, constant-amplitude pulse for operation of the start-stop trigger, V202. Trigger generator, V201, is a Schmitt Trigger with narrow hysteresis limits. A negative signal starts the action by causing the trigger generator to change state. This action generates a square wave output. This square wave output is differentiated by L201 into a series of positive and negative pulses. These pulses are fed to the start-stop trigger.

4-14. SAWTOOTH GENERATOR. The sawtooth generator consists of a start-stop trigger, an integrator switch, an integrator, and a hold-off cathode follower. The pulse from the trigger generator controls the start-stop trigger which, in turn, controls the integrator switch. The integrator switch controls the action of the integrator. The integrator generates a linear, rising voltage. This action plus the switching action of the integrator switch generates a sawtooth voltage. This sawtooth voltage is fed to the horizontal amplifier and to the hold-off cathode follower. The output of the hold-off cathode follower is fed to the grid of the start-stop trigger. This voltage keeps the start-stop trigger from triggering until all the circuits have had time to recover to their original quiescent voltage.

4-15. GATE CATHODE FOLLOWER. Another function of the sweep generator is to furnish a positive pulse to unblank the cathode-ray tube. This pulse is obtained from the start-stop trigger. Normally the voltage applied to the grid of the cathode-ray tube cuts off the beam. During the time of the sweep period a positive pulse is applied which overrides the negative voltage and unblanks the display.

4-16. HIGH VOLTAGE POWER SUPPLY.

4-17. The High Voltage Power Supply consists of a Hartley Oscillator driving two separate secondary windings and associated rectifiers. The Hartley Oscillator, pentode V302, is connected to the tapped primary winding of the high-voltage transformer. This circuit oscillates at approximately 100 kHz. The output of one of the rectifiers, V304, is connected to the grid of the CRT. The unblanking pulse is also directly-coupled to this supply and hence to the grid of the CRT. Output from rectifier V303 is connected to the cathode of the CRT. The INTENSITY control in the output divider of this supply determines the voltage on the CRT control grid and thus the brightness of the pattern. Voltage is taken from this supply and fed into the input of a two stage dc-coupled amplifier V301A & B. The output of this amplifier is fed back to the screen of the Hartley Oscillator in the proper phase to oppose any change in the dc output of the cathode supply. The INTENSITY MODULATION terminals are ac-coupled to the cathode of the CRT. A negative voltage input will brighten the trace while a positive voltage of approximately twenty volts will blank the tube from normal intensity.

4-18. LOW VOLTAGE POWER SUPPLY.

4-19. The Low Voltage Power Supply consists of three regulated supplies, one positive output, one negative output, and a dc heater supply.

4-20. POSITIVE VOLTAGE SUPPLY. This supply furnishes +380 volts and +100 volts. It consists of a transformer, four silicon rectifiers, a pentode amplifier and a triode regulator in a typical regulated power supply configuration. A triode cathode follower is included to drop the full output of +380 volts down to furnish +100 volts. Neon tube, V315, protects the cathode follower from excessive cathode-to-grid voltage during warmup.

4-21. NEGATIVE VOLTAGE SUPPLY. This supply furnishes -150 volts and -30 volts. It consists of a transformer, two silicon rectifiers, and a regulator-amplifier-reference tube combination in a typical regulated power supply configuration. The -30 volt output is used as a heater reference voltage.

4-22. REGULATED HEATER SUPPLY. This supply furnishes regulated +24 volts to the heaters of the four input tubes of the vertical amplifiers. These tubes, V1, V2, and V4, V5 are connected in series parallel. By supplying this filament voltage from a regulated dc source, vertical trace drift is greatly reduced. The supply consists of a transformer, a silicon rectifier, a transistor regulator, and a reference diode. The transistor is in series with the supply and the output voltage is applied to its base through the reference diode, CR308. The transistor, Q301, acts like a variable resistor which adjusts its resistance to maintain a constant voltage output.

Table 5-1. Required Test Equipment

Recommended Instrument	Required for	Required Characteristics
Voltmeter Calibrator hp Model 738B	Par. 5-9 Vert Amp Sensitivity Check Par. 5-15 Horiz Amp Sensitivity Check Par. 5-33 Chan B Gain Adj Par. 5-34 Chan A Gain Adj Par. 5-40 Horiz Gain Adj	300 μ v to 300 vdc or ac rms and pk-pk 400 Hz; 0.1% accuracy dc; 0.2% accuracy ac
Wide Range Oscillator hp Model 200CD	Par. 5-10 Vert Amp Bandwidth Check Par. 5-11 Vert Amp Common Signal Rejection Check Par. 5-16 Horiz Amp Bandwidth Check Par. 5-18 Sweep Generator Triggering Check Par. 5-26 EXT Trigger Sensitivity Adjustment Par. 5-36 Chan A Atten Compensation & B-A Common Mode Rejection Adjustment Par. 5-41 Square Wave Response Adjustment	Output frequency 40 Hz and 400 kHz
Vacuum Tube Voltmeter hp Model 400H	Par. 5-10 Vert Amp Bandwidth Check Par. 5-16 Horiz Amp Bandwidth Check Par. 5-18 Sweep Generator Triggering Check	1.0 mv to 300 v ranges; $\pm 1\%$ accuracy; 50 Hz to 500 kHz; input Z 10 meg shunted by 15 pf
Adjustable Attenuator hp Model 350D	Par. 5-11 Vert Amp Common Signal Rejection Check	110 db in 1 db steps; dc to 100 kHz ± 0.25 db Z = 600 ohms
Time Mark Generator Tektronix Type 180 or 184	Par. 5-19 Internal Sweep Time Check Par. 5-20 Expanded Sweep Calibration Check Par. 5-46 X1 Calibration Adjustment Par. 5-47 X5 Calibration Adjustment Par. 5-48 Sweep Linearity Adjustment Par. 5-49 50 μ sec/cm Sweep Adjustment Par. 5-50 0.5 ms/cm Sweep Adjustment Par. 5-51 50 ms/cm Sweep Adjustment Par. 5-52 Sweep Length Adjustment	Accurate markers from 1 μ sec to 5 sec
Vacuum Tube Voltmeter/ Ohmmeter hp Model 410B	Par. 5-24 Turn On Procedure Par. 5-28 Stability Adjustment	1 to 300 v ranges; dc to 700 MHz; $\pm 3\%$ accuracy; Input Z ac 10 meg shunted by 1.5 pf dc 122 megohms
Voltage Divider Probe hp Model 11045A	Par. 5-24 Turn On Procedure	100:1 division $\pm 5\%$; 12 meg-ohms input; (Calibrate to 1%)
Square Wave Generator hp Model 211A	Par. 5-35 Chan B Attenuator Compensation Adjustment Par. 5-42 Horiz Attenuator Compensation Adjustment	1 kHz output; 200 nsec rise time; > 50 v into 1 megohm

SECTION V MAINTENANCE

5-1. INTRODUCTION.

5-2. This section contains the performance check, Paragraph 5-5, adjustment procedures, Paragraph 5-21. Schematic diagrams, troubleshooting information, and Component Identification are in Section VIII.

5-3. TEST EQUIPMENT.

5-4. Test equipment required for maintaining and checking the performance of the Model 122A/AR is listed in Table 5-1. Test equipment having characteristics similar to those listed in the table may be substituted for the performance check and adjustments.

5-5. PERFORMANCE CHECK.

5-6. The performance check verifies whether or not the Model 122A/AR is operating within the specifications outlined in Table 1-1. This check may be used as part of an incoming quality control inspection, as a periodic operational check, or after repairs and/or adjustments have been made. Recently calibrated test equipment should be used when performing this check. If the instrument fails to meet a specification, carefully recheck instrument setup and the procedure; then if necessary, refer to the troubleshooting paragraphs or adjustment procedures. Refer to Section II for warranty and claims information. The performance check should be completed in the sequence given below. Do not attempt to start the procedure in mid-sequence, as succeeding steps are dependent upon control settings and results of previous steps.

5-7. VERTICAL AMPLIFIER.

5-8. ADJUST DC BALANCE AND VERTICAL CALIBRATION. A small screwdriver is required for this adjustment.

a. Check the vertical dc balance as shown in Figure 3-9.

b. Check the vertical sensitivity calibration as shown in Figure 3-10. If these controls do not function properly, refer to Vertical Amplifier adjustment procedures, Paragraph 5-30, before proceeding further.

5-9. VERTICAL AMPLIFIER SENSITIVITY. A Voltmeter Calibrator (such as hp Model 738B) is required for this check.

a. Set the Model 122A/AR controls:

VERT PRESENTATION A
A VERT SENSITIVITY . . . DC, .01 VOLTS/CM
A VERT SENSITIVITY VERNIER CAL
TRIGGER LEVEL . . . Max ccw, not in AUTO

b. Connect a 0.1 volt ac signal from the calibrator to input terminal A. The vertical trace should be 10 cm $\pm 3\%$ (9.7 - 10.3 cm). If not, refer to Vertical

Amplifier adjustment procedures, Paragraph 5-30, before proceeding further.

c. Check dc response by switching a 0.1 volt dc level from the calibrator off and on. As the voltage is switched off and on, the CRT spot should shift 10 cm $\pm 3\%$. Adjust VERTICAL POSITION as necessary.

d. Check the accuracy of the remaining positions of the attenuator. Table 5-2 lists the selector switch positions and gives the peak and rms voltage which should produce the deflection listed.

Table 5-2. Vertical Deflection Sensitivity

Sensitivity Volts/cm	Deflection cm $\pm 3\%$	Voltage Required	
		pk-pk	rms
0.01	5	0.05	0.01767
0.1	5	0.5	0.1767
1	5	5.0	1.767
10	5	50.0	17.67

e. Repeat steps c and d using the ac ranges.

f. Repeat above procedure for channel B.

5-10. VERTICAL AMPLIFIER BANDWIDTH. A Wide Range Oscillator (such as hp Model 200CD) and a Vacuum Tube Voltmeter (such as hp Model 400H) are required for this check.

a. Set the Model 122A/AR controls:

VERT PRESENTATION A
A VERT SENSITIVITY01 VOLTS/CM
TRIGGER LEVEL AUTO

b. Connect the oscillator to input terminal A, and set it to 2 kHz; adjust for 10 cm of deflection. Note reading on the vtm.

c. Set the oscillator to 200 kHz and output to previous reading on the vtm. The deflection should be at least 7.07 cm (3 db down point).

d. Repeat above procedures for channel B.

5-11. VERTICAL AMPLIFIER COMMON-SIGNAL REJECTION. A Wide Range Oscillator (such as hp Model 200CD) and an Adjustable Attenuator (such as hp Model 350D) are required for this check.

a. Set the Model 122A/AR controls:

A VERT SENSITIVITY01 VOLTS/CM
A VERT SENSITIVITY VERNIER CAL
SWEEP TIME5 MILLISEC/CM
VERT PRESENTATION A
TRIGGER LEVEL AUTO
SYNC INT

b. Connect the oscillator to the channel A input terminal through the adjustable attenuator terminated with 600 ohms.

c. With the oscillator set to 1 kHz and maximum output, switch the attenuator into the circuit until 1 cm of deflection is displayed.

d. Change input so that the same signal is fed into both red input terminals. Remove ground strap and connect ground side of oscillator to black terminal.

e. Switch the adjustable attenuator (reducing attenuation) until a deflection of 1 cm is again obtained. The attenuation change is the common-signal rejection and should be at least 40 db.

f. Repeat the above procedure for channel B.

5-12. VERTICAL AMPLIFIER COMMON-SIGNAL REJECTION (B-A). A Wide Range Oscillator (such as hp Model 200CD) is required for this check.

a. Set the Model 122A/AR controls:

A VERT SENSITIVITY 10 VOLTS/CM
B VERT SENSITIVITY 10 VOLTS/CM
B VERT SENSITIVITY VERNIER CAL
SWEEP TIME5 MILLISEC/CM
VERT PRESENTATION B

b. Connect the oscillator to both the Channel A and Channel B input terminals.

c. Set the oscillator to 2 kHz and adjust its output to display at 5 cm deflection.

d. Switch VERT PRESENTATION to B-A. Deflection should be less than 0.2 cm.

e. Set A and B VERT SENSITIVITY to 1 VOLT and readjust the oscillator output for 5 cm deflection. B-A presentation should be less than 0.2 cm.

f. Switch A VERT SENSITIVITY and B VERT SENSITIVITY to .1 VOLTS/CM and readjust the oscillator output for 5 cm of deflection. B-A presentation should be less than 0.2 cm of deflection.

g. Repeat steps above using 200 kHz output from the oscillator. Limits are the same as in the 2 kHz check.

h. If the instrument fails to meet any of these limits consult the appropriate part of the Vertical Amplifier adjustment procedures, Paragraph 5-30.

5-13. DUAL TRACE PRESENTATION. No test equipment is required.

a. Set the Model 122A/AR controls:

TRIGGER LEVEL AUTO
SYNC INT
VERT PRESENTATION CHOP
SWEEP TIME 50 MILLISEC/CM
A VERT SENSITIVITY OFF
B VERT SENSITIVITY OFF

b. Adjust remaining oscilloscope controls to display the chopped trace.

c. The A VERTICAL POSITION control should move one chopped trace and the B VERTICAL POSITION control should move the other.

d. Set VERT PRESENTATION to ALT. The Channel A and Channel B traces should be displayed alternately.

5-14. HORIZONTAL AMPLIFIER.

5-15. HORIZONTAL AMPLIFIER SENSITIVITY. A Voltmeter Calibrator (such as hp Model 738B) is required for this check.

a. Set the Model 122A/AR controls:

HORIZ SENS1 VOLTS/CM
HORIZ SENS VERNIER CAL
VERT PRESENTATION A
DC-AC (horizontal input coupling) DC

b. Connect the Voltmeter Calibrator, set for 1.0 volt 400 Hz peak-to-peak, to the horizontal input terminals. Adjust the position controls to center the horizontal trace. The trace should be 10 cm \pm 5% long (9.5 - 10.5 cm). If not, refer to the Horizontal Amplifier adjustment procedures, Paragraph 5-38.

c. Check the dc response by switching a 0.1 volt dc voltage from the voltmeter calibrator off and on. As the voltage is switched off and on, the CRT spot should shift 10 cm \pm 5%. Adjust A VERTICAL POSITION as necessary.

d. Check the accuracy of the remaining VOLTS/CM positions as shown in Table 5-3.

Table 5-3. Horizontal Deflection Sensitivity

Sensitivity Volts/cm	Voltage for 10 (\pm 5%) cm Deflection	
	pk-pk	rms
0.1	1.0	0.3535
1.0	10.0	3.535
10.0	100.0	35.35

5-16. HORIZONTAL AMPLIFIER BANDWIDTH. A Wide Range Oscillator (such as hp Model 200CD) and a Vacuum Tube Voltmeter (such as hp Model 400H) are required for this check.

a. Set the Model 122A/AR controls:

HORIZ SENS1 VOLTS/CM
TRIGGER LEVEL AUTO

b. Connect the oscillator to the oscilloscope horizontal input terminals. Monitor the sine wave amplitude with the vtvm.

c. Adjust the remaining oscilloscope controls to display the horizontal trace.

d. Set the oscillator to 2 kHz and adjust for a 10 cm deflection. Note the reading on the vtvm.

e. Set the oscillator to 200 kHz. Set output to previous reading on the vtvm. The deflection should now be at least 7.07 cm (3 db down point). If not, refer to the Horizontal Amplifier adjustment procedures, Paragraph 5-38.

5-17. SWEEP GENERATOR.

5-18. SWEEP GENERATOR TRIGGERING. A Wide Range Oscillator (such as hp Model 200CD) and a Vacuum Tube Voltmeter (such as hp Model 400H) are required for this check.

- a. Set the Model 122A/AR controls:
 SYNC INT
 TRIGGER LEVEL AUTO
 A VERT SENSITIVITY 1 VOLTS/CM
 A VERT SENSITIVITY VERNIER CAL
 VERT PRESENTATION A
- b. Connect the oscillator, set for approximately 0.5 v rms, 400 Hz, to the oscilloscope vertical input.
- c. Adjust remaining oscilloscope controls to display a few cycles of signal.
- d. Decrease the input from the oscillator until the pattern goes out of synchronization. The pattern should be 0.5 cm high or less.
- e. Connect the oscillator to the external synchronization terminals and to the oscilloscope input. Monitor the sine wave amplitude with the vtvm.
- f. Set SYNC switch to EXT.
- g. Decrease the amplitude of the oscillator until the pattern goes out of synchronization. The reading on the vtvm should be 0.885 volts or less.
- h. If the oscilloscope fails to meet either check, refer to the Sweep Generator adjustment procedures, Paragraph 5-44.

5-19. INTERNAL SWEEP TIME. A Time Mark Generator (such as Tektronix Type 180) is required for this check.

- a. Set the Model 122A/AR controls:
 SWEEP TIME 1 MILLISEC/CM
 SWEEP TIME VERNIER CAL
 SYNC INT
 TRIGGER LEVEL AUTO
 SWP EXP X1

b. Connect the output of the Time Mark Generator to the oscilloscope vertical input. Set the Time Mark Generator for 1/1000 sec or a 1 millisecond period. Adjust remaining oscilloscope controls to display the signal with a vertically centered peak-to-peak deflection of 4 to 6 cm. This signal should produce 10 cycles in 10 ±5% (9.5 - 10.5) cm of horizontal deflection.

c. Each step of the SWEEP TIME selector is checked using the method outlined above. Table 5-4 provides complete information on selector position, frequency or period of the timing signal and the number of cycles of the signal produced in 9.5 - 10.5 cm of horizontal deflection. If your oscilloscope does not meet these checks, refer to the Sweep Generator adjustment procedures, Paragraph 5-44.

5-20. EXPANDED SWEEP CALIBRATION. A Time Mark Generator (such as Tektronix Type 180) is required for this check.

- a. Set the Model 122A/AR controls:
 SWEEP TIME 1 MILLISEC/CM
 SWEEP TIME VERNIER CAL
 SYNC INT
 TRIGGER LEVEL AUTO
 SWP EXP X1

b. Connect the output of the Time Mark Generator to the oscilloscope vertical input. Set the Time Mark Generator for 1/1000 sec or a 1 millisecond period. Adjust remaining oscilloscope controls to display the signal with a vertically centered peak-to-peak deflection of 4 to 6 cm. This signal should produce 10 cycles in 10 ±5% centimeters of horizontal deflection.

c. Set SWP EXP switch to X5. Two complete cycles should now appear in 10 ±5% centimeters of horizontal deflection.

Table 5-4. Sweep Time Accuracy

SWEEP TIME Position	Timing Signal		Cycles Produced in 9.5 to 10.5 cm
	Frequency	Period	
*200 MILLISEC/CM	1 Hz	1 second	2
100 MILLISEC/CM	10 Hz	100 milliseconds	10
50 MILLISEC/CM	10 Hz	100 milliseconds	5
20 MILLISEC/CM	10 Hz	100 milliseconds	2
10 MILLISEC/CM	100 Hz	10 milliseconds	10
5 MILLISEC/CM	100 Hz	10 milliseconds	5
2 MILLISEC/CM	100 Hz	10 milliseconds	2
1 MILLISEC/CM	1,000 Hz	1 millisecond	10
.5 MILLISEC/CM	1,000 Hz	1 millisecond	5
200 μSEC/CM	1,000 Hz	1 millisecond	2
100 μSEC/CM	10 kHz	100 microseconds	10
50 μSEC/CM	10 kHz	100 microseconds	5
20 μSEC/CM	10 kHz	100 microseconds	2
10 μSEC/CM	100 kHz	10 microseconds	10
5 μSEC/CM	100 kHz	10 microseconds	5

*Use DC input coupling to avoid degrading the input signal.

5-21. ADJUSTMENTS.

5-22. Table 5-1 lists the test equipment required to make these adjustments. Equipment having the required characteristics may be substituted for that listed. Equipment required for each procedure is also listed at the beginning of that procedure. Usually a particular oscilloscope will not need complete testing and calibration. Only one or two tests will be needed and they can be done without completing the entire test procedure.

5-23. The Model 122A/AR and the test equipment to be used should be turned on and allowed to warm up for 30 minutes before making the adjustments. (Figures 5-1, 5-2, and 8-2 identify various adjustments and their locations.) The following procedures are listed in a recommended sequence for a complete test and calibration of the instrument. In general, tubes are the main cause of trouble and new ones should be tried before making adjustments or component replacements.

5-24. TURN ON PROCEDURE.

5-25. Perform this procedure only after repair work has been done on the instrument. The purpose of this procedure is to check that none of the power supplies have been shorted and to serve as a partial check upon the correctness of the repairs that have been made.

a. Measure, as shown in Table 5-5, from the power supplies to chassis ground. A vacuum tube voltmeter/ohmmeter (such as hp Model 410B) should be used for these measurements. When turning the oscilloscope on for the first time after repair in any of the power supply circuits, turn the INTENSITY control to its lowest (ccw) position to prevent possible damage to the CRT during warm-up. If you are able to get a small, round, and sharply focused spot with good brilliance by adjusting the controls, the high voltage power supply can be assumed to be operating properly.

Table 5-5. Low Voltage Power Supply Tolerances

Power Supply	Voltages	Resistances
+380	365 - 395	75k ohms
+100	97 - 103	120k ohms
-150	135 - 175 (adj R344)	14k ohms
+24	22.5 - 25	2.2k ohms*

*With V1, V2, V4 and V5 removed from sockets

b. Measure resistances to chassis ground into the vertical and horizontal input terminals for all dc switch positions. These resistances should be 1 megohm. When switched to the OFF or CAL positions, the resistance readings should be infinity.

c. If necessary, the high voltage can be adjusted by R308 (see Figure 8-2). This voltage should be approximately -2250 as measured with a vtm and voltage divider probe (such as hp Model 410B vtm and hp Model 11045A Divider Probe). Make this measurement on the rectifier terminal with the orange wire.

WARNING

HIGH VOLTAGE, DANGEROUS TO HUMAN LIFE!

(If the high voltage is changed, it may be necessary to recalibrate the Vertical and Horizontal amplifier gains, as covered in Paragraphs 5-33, 5-34, and 5-40.)

d. Adjust FOCUS control and Astigmatism adjustment, R316 (see Figure 5-1) at a low setting of the INTENSITY control to obtain a small, round, and sharply focused spot.

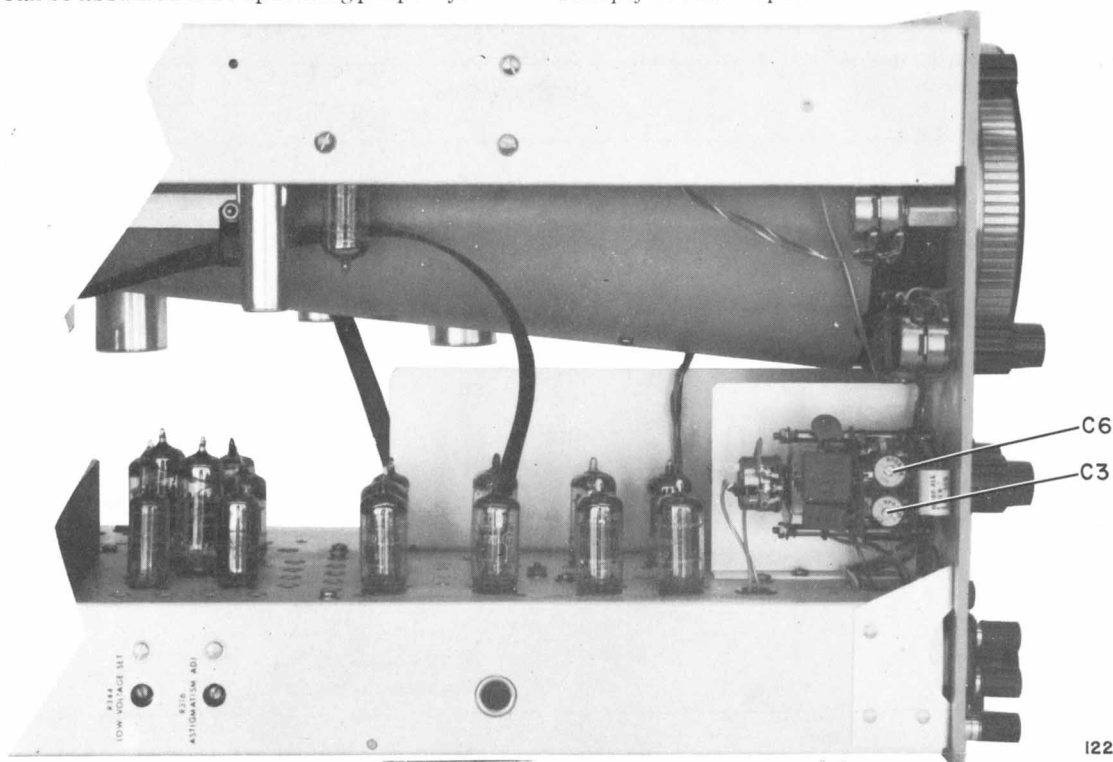

Figure 5-1. Left-Side Adjustment Location Diagram

122A-A-1

e. Adjust the SCALE potentiometer on the front panel to align a finely-focused horizontal trace with the horizontal lines of the graticule. Repeat this adjustment whenever necessary due to changes in the location of the instrument or the influence of fields generated by nearby electrical equipment.

5-26. TRIGGER GENERATOR

5-27. The Trigger Generator circuit must be properly adjusted before the Vertical and Horizontal Amplifiers can be adjusted. Also, these Amplifiers must be properly adjusted before the Sawtooth Generator can be adjusted. The Trigger Generator circuit is adjusted as follows.

5-28. STABILITY ADJUSTMENT. A vacuum tube voltmeter/ohmmeter (such as hp Model 410B) and a small screwdriver are required for this adjustment.

- a. Set the Model 122A/AR controls:
A VERT SENSITIVITY OFF
B VERT SENSITIVITY OFF
SWEEP TIME 5 MILLISEC/CM
SYNC INT
TRIGGER LEVEL . fully ccw, but not on AUTO
VERT PRESENTATION A or B

b. Connect the vtm (-100 v dc range) to pin 8 of V203. Slowly rotate Stability control R228 (see Figure 5-2) ccw until the sweep starts free-running, then back control off until it just stops.

c. Take voltage reading (which should be approximately - 78 volts). Adjust R228 for a reading 3 volts more positive than the last reading.

5-29. EXTERNAL TRIGGER SENSITIVITY ADJUSTMENT. A wide range oscillator (such as hp Model 200CD), a test oscilloscope, and a small screwdriver are required for this adjustment.

- a. Set the Model 122A/AR controls:
SYNC EXT
TRIGGER LEVEL AUTO
DC/AC DC
VERT PRESENTATION A or B
Trigger Sens R247 fully ccw

b. Connect a 250 kHz sine-wave of 0.7 v rms to the SYNC external input terminals, and observe the square wave by clipping the test oscilloscope probe over the body of R204 (V201A plate resistor).

c. Increase Trigger Sens control R247 (see Figure 5-2) until stable triggers are obtained. Check trigger sensitivity from 50 Hz to 250 kHz. Stable triggering should be obtained with less than 0.7 v rms over this range.

d. Remove the test set-up and check the rate when the TRIGGER LEVEL control is in the AUTO position (should be approximately 120 ± 50Hz).

5-30. VERTICAL AMPLIFIERS.

5-31. CHANNEL B BALANCE ADJUSTMENT. A small screwdriver is required for this adjustment.

- a. Set the Model 122A/AR controls:
VERT PRESENTATION B
B VERT SENSITIVITY . AC, 0.01 VOLTS/CM
HORIZ SENSITIVITY 10 VOLTS/CM

- B INPUT Shorted
B VERT SENSITIVITY VERNIER ccw

b. Adjust spot to center of screen with B VERTICAL POSITION control.

c. Turn B VERT SENSITIVITY VERNIER fully clockwise and readjust spot to center with B BAL adjusting screw.

d. Repeat this sequence until there is no displacement of spot as VERNIER is rotated.

e. Set B VERTICAL POSITION control to its center (12 o'clock). Spot should now be on screen, near center.

5-32. CHANNEL A BALANCE ADJUSTMENT. A small screwdriver is required for this adjustment.

- a. Set the Model 122A/AR controls:
VERT PRESENTATION A
A VERT SENSITIVITY . AC, 0.01 VOLTS/CM
HORIZ SENSITIVITY 10 VOLTS/CM
A INPUT Shorted
A VERT SENSITIVITY VERNIER . . fully ccw

b. Adjust spot to center of screen with A VERTICAL POSITION control.

c. Turn A VERT SENSITIVITY VERNIER control fully clockwise and readjust spot to center with A BAL adjusting screw.

d. Repeat this sequence until there is no displacement of spot as VERNIER is rotated.

e. Set A VERTICAL POSITION control to its center (12 o'clock). Spot should now be on screen, near center.

5-33. CHANNEL B GAIN ADJUSTMENT. A Voltmeter Calibrator (such as hp Model 738B) and a small screwdriver are required for this adjustment.

- a. Set the Model 122A/AR controls:
VERT PRESENTATION B
B VERT SENSITIVITY . AC, 0.01 VOLTS/CM
B VERT SENSITIVITY VERNIER CAL

b. Connect 100 millivolt peak-to-peak signal from the Voltmeter Calibrator into channel B input terminals.

c. Set GAIN adjustment screw of Channel B to give exactly 10 centimeters of deflection.

d. Check this setting at 127 (or 254) and 103 (or 206) volts line input. Gain should be within 3% at all line voltages. If not, check power supplies and vertical amplifier tubes.

5-34. CHANNEL A GAIN ADJUSTMENT. A Voltmeter Calibrator (such as hp Model 738B) and a small screwdriver are required for this adjustment.

- a. Set the Model 122A/AR controls:
VERT PRESENTATION A
A VERT SENSITIVITY . . AC, 0.01 VOLTS/CM
A VERT SENSITIVITY VERNIER CAL

b. Connect 100 millivolt peak-to-peak signal from the Voltmeter Calibrator into channel A input terminals, and repeat the procedure outlined in Paragraph 5-33, adjusting channel A GAIN.

5-35. CHANNEL B ATTENUATOR COMPENSATION ADJUSTMENT. A Square Wave Generator (such as hp Model 211A) and a small screwdriver are required for this adjustment. (Access to C13, C16, and C18 on Model 122A is through a rectangular opening in the chassis below the channel B attenuator assembly.)

a. Set the Model 122A/AR controls:

B VERT SENSITIVITY . . . DC, 0.01 VOLTS/CM
 B VERT SENSITIVITY VERNIER CAL
 SYNC INT+
 TRIGGER LEVEL AUTO
 SWEEP TIME 200μSEC/CM
 VERT PRESENTATION B

b. Connect a 5 kHz square wave signal to channel B input terminals. Adjust level for an 8 cm vertical deflection. Adjust C13 on channel B vertical attenuator for a flat-topped square wave.

c. Switch B VERT SENSITIVITY to 1 VOLTS/CM and increase input level to give 8 cm deflection. Adjust C16 for flat response.

d. Switch B VERT SENSITIVITY to 10 VOLTS/CM and apply full output of square wave generator to input. Adjust C18 for flat response.

e. Switch back through the four attenuator positions and check for 10:1 divisions (should be within 2%).

5-36. CHANNEL A ATTENUATOR COMPENSATION AND B-A COMMON MODE REJECTION ADJUSTMENT. A Sine Wave Oscillator (such as hp Model 200CD) and a small screwdriver are required for this adjustment.

a. Set the Model 122A/AR controls:

A & B VERT SENSITIVITY
 DC, 0.1 VOLTS/CM

A & B VERT SENSITIVITY VERNIER . . . CAL
 SYNC INT+
 TRIGGER LEVEL AUTO
 SWEEP TIME 200μSEC/CM
 VERT PRESENTATION B-A

b. Apply a 200 kHz sine wave to both channels A and B vertical input terminals from the oscillator set for 20-25 volts. Adjust C3 (see Figure 5-1) on channel A attenuator for minimum deflection.

c. Set both A and B VERT SENSITIVITY controls to 1 VOLTS/CM and adjust C6 (see Figure 5-1) on Channel A attenuator for minimum deflection.

d. Set both A and B VERT SENSITIVITY controls to 10 VOLTS/CM and adjust C8 for minimum deflection.

e. Set VERT PRESENTATION to A and A VERT SENSITIVITY to DC, 0.1 VOLTS/CM.

f. Apply a 5 kHz square wave to channel A input and adjust level for 8 cm deflection. Adjust C22 on VERT PRESENTATION switch for flat response.

5-37. CALIBRATOR AMPLITUDE ADJUSTMENT. A small screwdriver is required for this adjustment.

Note

Channel A gain should have been adjusted before amplitude adjustments.

a. Set the Model 122A/AR controls:

A & B VERT SENSITIVITY CAL
 A & B VERT SENSITIVITY VERNIER . . . CAL
 VERT PRESENTATION A
 TRIGGER LEVEL AUTO

b. Adjust Calibrator set, R356, (see Figure 5-2) for exactly 6 cm of vertical deflection.

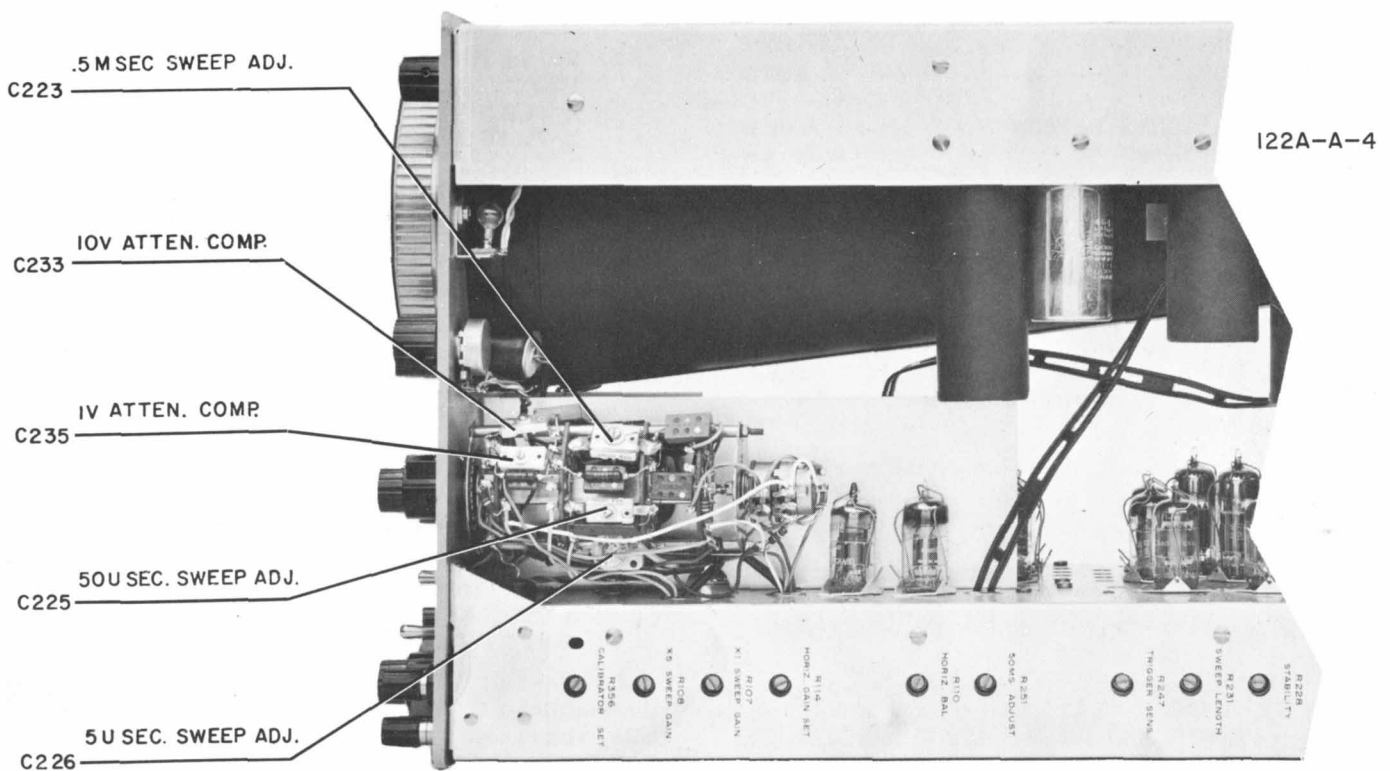

Figure 5-2. Right-Side Adjustment Location Diagram

5-38. HORIZONTAL AMPLIFIER.

5-39. BALANCE ADJUSTMENT. A small screwdriver is required for this adjustment.

- a. Set the Model 122A/AR controls:
 HORIZ SENS 0.1 VOLTS/CM
 HORIZ SENS VERNIER CAL
 Input toggle switch DC
- b. Place shorting jumper across the horizontal input terminals.
- c. Adjust the spot to center of screen with HORIZ POSITION control.
- d. Turn HORIZ SENS VERNIER fully counterclockwise and readjust position of spot with Horizontal Balance Adjustment, R110.
- e. Turn HORIZ SENS VERNIER to CAL and center spot with HORIZ POSITION control to center (12 o' clock). The spot should now be on the screen near center.

5-40. HORIZONTAL GAIN ADJUSTMENT. A Voltmeter Calibrator (such as hp Model 738B) and a small screwdriver are required for this adjustment.

- a. Set the Model 122A/AR controls:
 HORIZ SENS 0.1 VOLTS/CM
 HORIZ SENS VERNIER CAL
- b. Apply 1.0 volt peak-to-peak signal from the voltmeter Calibrator to the horizontal input terminals.
- c. Set the Horiz Gain Adjustment, R114 (see Figure 5-2), for exactly 10 cm of deflection.
- d. Check this setting at high and low line voltages, as outlined in Paragraph 5-33, d. Setting of Gain Adjustment should be within 3% at all line voltages. If not, check power supplies and horizontal amplifier tubes.

5-41. SQUARE WAVE RESPONSE ADJUSTMENT. A Sine Wave Oscillator (such as hp Model 200CD) and a Square Wave Generator (such as hp Model 211A) and a small screwdriver are required for this adjustment.

- a. Set the Model 122A/AR controls:
 HORIZ SENS 0.1 VOLTS/CM
 HORIZ SENS VERNIER CAL
 VERT PRESENTATION B
- b. Connect 8 kHz (approximately) sine wave signal to channel B vertical input terminals and to the SYNC IN terminals of the Square Wave Generator.
- c. Adjust the output of the oscillator for a 10 cm deflection.
- d. Apply a 50 kHz square wave signal to Horizontal input terminals and adjust the square wave amplitude for 6 to 8 cm deflection.
- e. Adjust C110 (see Figure 8-2) for best square wave response. A maximum of 2% overshoot is permitted.

5-42. ATTENUATOR COMPENSATION ADJUSTMENT. A Sine Wave Oscillator (such as hp Model 200CD) and a Square Wave Generator (such as hp Model 211A or 212A) and a small screwdriver are required for these adjustments.

- a. Set the Model 122A/AR controls:
 HORIZ SENS 1 VOLTS/CM
 HORIZ SENS VERNIER CAL
 VERT PRESENTATION B
- b. Connect 800 Hz (approximately) sine wave to channel B vertical input terminals and sync-in terminal of square wave generator.
- c. Adjust the output of the oscillator for a 10 cm deflection.
- d. Connect a 5kHz square wave signal to horizontal input terminals and adjust the square wave amplitude for 6 to 8 cm deflection.
- e. Adjust C235 (see Figure 5-2) on SWEEP TIME switch for flat response.
- f. Set HORIZ SENS to 10 VOLTS/CM, increase input to display 6 to 8 cm deflection, and adjust C233 for flat response.

g. Now switch back through the three attenuator ranges and check for 10:1 division. Division should be within 5%.
5-43. PHASE ADJUSTMENT. A Sine Wave Oscillator (such as hp Model 200CD) and a small screwdriver are required for these adjustments.

- a. Set the Model 122A/AR controls:
 HORIZ SENS 0.1 VOLTS/CM
 HORIZ SENS VERNIER CAL
 A & B VERT SENSITIVITY 0.1 VOLTS/CM
 A & B VERT SENSITIVITY VERNIER CAL
 VERT PRESENTATION CHOP
- b. Apply a 100 kHz sine wave to both channel A and channel B input terminals, and to the horizontal input terminals.
- c. Adjust amplitude to give about 6 cm deflection along both axes.
- d. Adjust C107 (see Figure 8-2) for best closure of the B pattern.
- e. Adjust C44 for best closure of the A pattern.
- f. Switch channels A and B and HORIZ SENS to 10 V/CM range.
- g. Readjust Sine Wave Oscillator to display approximately 6 cm deflection in both axes.
- h. Readjust C8 (chan A) and C18 (chan B) for best closure of patterns.
- i. Check phase shift on the attenuated ranges.

5-44. SWEEP GENERATOR.

5-45. The Vertical and Horizontal amplifiers must be satisfactorily adjusted before the Sweep Generator Adjustment can be completed.

5-46. X1 CALIBRATION ADJUSTMENT. A Time Mark Generator (such as Tektronix Type 180 or 184) and a small screwdriver are required for the adjustments covered in this and following paragraphs.

- a. Set the Model 122A/AR controls:
 SWEEP TIME 10 MILLISEC/CM
 VERNIER CAL
 SWP EXP X1

b. Apply a 10-millisecond time marker to the Vertical Input terminals.

c. Adjust TRIGGER LEVEL control and choose either INT+ or INT- for best presentation.

d. Adjust X1 Sweep Gain Adjustment, R107 (see Figure 5-2), so that the markers coincide with every major division on the graticule (1 marker/cm).

5-47. X5 CALIBRATION ADJUSTMENT. (Use same test equipment as outlined in Paragraph 5-46.)

a. Set SWP EXP to X5.

b. Apply 10-millisecond time marker signals to Vertical Input terminals.

c. Adjust TRIGGER LEVEL control for best presentation.

d. Adjust X5 Sweep Gain Adjustment, R108 (see Figure 5-2), for 1 marker per 5 centimeters.

5-48. SWEEP LINEARITY ADJUSTMENT. (Use same test equipment as outlined in Paragraph 5-46.)

a. Set the Model 122A/AR controls:

SWEEP TIME 10μSEC/CM
VERNIER CAL
SWP EXP X1

b. Apply a 10-microsecond time marker signal to the vertical input terminals.

c. Adjust TRIGGER LEVEL control for best presentation.

d. Adjust HORIZ POSITION control so last marker on the trace is aligned with last graticule marking.

e. Adjust C226 (see Figure 5-2) so that last five markers coincide with every major graticule division (1 marker/cm).

f. Set R231, Sweep Length, to obtain approximately 10 cm of sweep.

g. Adjust C214 (see Figure 8-2) so that first five markers on the trace coincide with every major graticule division. If necessary, adjust HORIZ POSITION control so that last marker on the trace is always aligned with last graticule marking.

h. Change SWEEP TIME switch to 5μSEC/CM and apply a 1-microsecond time marker to Vertical Input terminals.

i. Adjust VERT SENSITIVITY, SYNC, and TRIGGER LEVEL for best presentation.

j. Adjust HORIZ POSITION control so that sweep starts on left-hand graticule mark.

k. Adjust C105 (see Figure 8-2) for equal spacing of markers on first portion of sweep (5 markers/cm).

m. Change SWEEP TIME switch to 20μSEC/CM and SWP EXP to X5.

n. Apply 1-microsecond time marker signal to Vertical Input terminals and adjust for best presentation.

p. Adjust HORIZ POSITION control so that sweep starts on left-hand graticule mark.

q. Adjust C106 (see Figure 8-2) for equal spacing of marker on first portion (4 markers/cm).

5-49. 50-μSEC/CM SWEEP ADJUSTMENT. (Use same test equipment as outlined in Paragraph 5-46.)

a. Set the Model 122A/AR controls:

SWEEP TIME 50μSEC/CM
VERNIER CAL
SWP EXP X1

b. Apply 100-microsecond time marker signal to Vertical Input terminals.

c. Adjust TRIGGER LEVEL control for best presentation

d. Adjust C225 (see Figure 5-2) for marker coincidence with every other major graticule division (1 marker/2 cm).

5-50. 0.5-MILLISEC/CM SWEEP ADJUSTMENT. (Use same test equipment as outlined in Paragraph 5-46.)

a. Set the Model 122A/AR controls:

SWEEP TIME 0.5 MILLISEC/CM
VERNIER CAL
SWP EXP X1

b. Apply 1-millisecond marker signal to Vertical Input terminals.

c. Adjust VERT SENSITIVITY, SYNC, and TRIGGER LEVEL for best presentation.

d. Adjust C223 (see Figure 5-2) for marker coincidence with every other major graticule division (1 marker/2 cm).

5-51. 50-MILLISEC/CM SWEEP ADJUSTMENT. (Use same test equipment as outlined in Paragraph 5-46.)

a. Set the Model 122A/AR controls:

SWEEP TIME 50 MILLISEC/CM
VERNIER CAL
SWP EXP X1

b. Adjust VERT SENSITIVITY, SYNC, and TRIGGER LEVEL for best presentation.

c. Adjust R251 (see Figure 5-2), 50 msec Adjust, for marker coincidence with every other major graticule division (1 marker/cm).

5-52. SWEEP LENGTH ADJUSTMENT. (Use same test equipment as outlined in Paragraph 5-46.)

a. Set the Model 122A/AR controls:

SWEEP TIME 1 MILLISEC/CM
VERNIER CAL
SWP EXP X1

b. Apply 1-microsecond marker to the Vertical Input terminals.

c. Adjust VERT SENSITIVITY, SYNC, and TRIGGER LEVEL for best presentation.

d. Adjust R231 (see Figure 5-2), Sweep Length, for 10.5 cm of sweep.

SECTION VI REPLACEABLE PARTS

6-1. INTRODUCTION.

6-2. This section contains information for ordering replaceable parts for the Model 122A/AR. Table 6-1 lists reference designators and abbreviations that are used in the Table 6-2 component descriptions. Table 6-2 lists the parts in alpha-numerical order of their reference designations and provides the following information for each item:

- a. The hp part number.
- b. Total quantity (TQ) used in the instrument; given only first time the part number is listed.
- c. Description of part (refer to Table 6-1).

6-3. Parts not identified by a reference designation are listed at the end of Table 6-2, under miscellaneous. Cabinet Model 122A and Rack Model 122AR are pictured in Figure 1-1.

6-4. ORDERING INFORMATION.

6-5. To order replacement parts from the Hewlett-Packard Company, address the order or inquiry to

the nearest hp Sales/Service Office (see list of addresses at rear of this manual) and supply the following information:

- a. The hp part number of item (s).
- b. Model number and eight-digit serial number of the instrument.
- c. Quantity of parts desired.

6-6. To order a part not listed in Table 6-2, provide the following information:

- a. Model number and eight-digit serial number of the instrument.
- b. Description of part including function and location.

Note

Upon request, information will be supplied to allow ordering applicable parts from a manufacturer other than Hewlett-Packard. Contact the hp Sales/Service Office for details.

Table 6-1. Reference Designators and Abbreviations

REFERENCE DESIGNATORS			
<p>A = assembly B = motor C = capacitor CP = coupling CR = diode DL = delay line DS = device signaling (lamp)</p>	<p>E = misc electronic part F = fuse FL = filter J = jack K = relay L = inductor M = meter</p>	<p>MP = mechanical part P = plug Q = transistor R = resistor RT = thermistor S = switch T = transformer</p>	<p>TB = terminal board TP = test point V = vacuum tube, neon bulb, photocell, etc W = cable X = socket Y = crystal</p>
ABBREVIATIONS			
<p>A = amperes A.F.C = automatic frequency control AMPL = amplifier</p> <p>B. F. O. = beat frequency oscillator BE CU = beryllium copper BH = binder head BP = bandpass BRS = brass BWO = backward wave oscillator</p> <p>CCW = counter-clockwise CER = ceramic CMO = cabinet mount only COEF = coefficient COM = common COMP = composition CONN = connector CP = cadmium plate CRT = cathode-ray tube CW = clockwise</p> <p>DEPC = deposited carbon DR = drive</p> <p>ELECT = electrolytic ENCAP = encapsulated EXT = external</p> <p>F = farads FH = flat head FIL H = fillister head FXD = fixed</p>	<p>GE = germanium GL = glass GRD = ground(ed)</p> <p>H = henries HEX = hexagonal HG = mercury HR = hour(s) hp = Hewlett-Packard IF = intermediate freq IMPG = impregnated INCD = incandescent INCL = include(s) INS = insulation(ed) INT = internal</p> <p>K = kilo = 1000</p> <p>LIN = linear taper LK WASH = lock washer LOG = logarithmic taper LPF = low pass filter</p> <p>M = milli = 10⁻³ MEG = meg = 10⁶ METFLM = metal film MFR = manufacturer MINAT = miniature MOM = momentary MTG = mounting MY = "mylar"</p> <p>N = nano (10⁻⁹)</p>	<p>N/C = normally closed NE = neon NI PL = nickel plate N/O = normally open NPO = negative positive zero (zero temperature coefficient) NRFR = not recommended for field replacement NSR = not separately replaceable</p> <p>OBD = order by description OH = oval head OX = oxide</p> <p>P = peak PC = printed circuit PF = picofarads = 10⁻¹² farads PH BRZ = phosphor bronze PHL = Phillips PIV = peak inverse voltage P/O = part of POLY = polystyrene PORC = porcelain POS = position(s) POT = potentiometer PP = peak-to-peak PT = point RECT = rectifier RF = radio frequency RH = round head</p>	<p>RMO = rack mount only RMS = root-mean-square</p> <p>S-B = slow-blow SCR = screw SE = selenium SECT = section(s) SEMICON = semiconductor SI = silicon SIL = silver SL = slide SPL = special SST = stainless steel SR = split ring STL = steel</p> <p>TA = tantalum TD = time delay TGL = toggle TI = titanium TOL = tolerance TRIM = trimmer TWT = traveling wave tube</p> <p>U = micro = 10⁻⁶</p> <p>VAR = variable VDCW = dc working volts</p> <p>W/ = with W = watts WW = wirewound W/O = without</p>

Table 6-2. Replaceable Parts

Ref Desig	hp Part No.	RS	TQ	Description (See Table 6-1.)
C1	0170-0022		2	C: fxd my 0.1 μ f 20% 600vdcw
C2	0140-0042		2	C: fxd mica 27 pf 5% 500vdcw
C3	0130-0012		5	C: var cer 5-25 pf
C4	0140-0030		2	C: fxd mica 390 pf 10% 500vdcw
C5	0140-0004		5	C: fxd mica 15 pf 10% 500vdcw
C6	0130-0012			C: var cer 5-25 pf
C7	0140-0029		2	C: fxd mica 3300 pf 10% 500vdcw
C8	0132-0004		2	C: var poly 0.7-3 pf 350vdcw
C9	0160-2103		2	C: fxd cer 0.002 μ f 20% 1000vdcw
C10	0150-0012		13	C: fxd cer 0.01 μ f 20% 1000vdcw
C11	0170-0022			C: fxd my 0.1 μ f 20% 600vdcw
C12	0140-0042			C: fxd mica 27 pf 5% 500vdcw
C13	0130-0012			C: var cer 5-25 pf
C14	0140-0030			C: fxd mica 390 pf 10% 500vdcw
C15	0140-0004			C: fxd mica 15 pf 10% 500vdcw
C16	0130-0012			C: var cer 5-25 pf
C17	0140-0029			C: fxd mica 3300 pf 10% 500vdcw
C18	0132-0004			C: var poly 0.7-3 pf 350vdcw
C19	0160-2103			C: fxd cer 0.002 μ f 20% 1000vdcw
C20	0150-0012			C: fxd cer 0.01 μ f 20% 1000vdcw
C21	0140-0001		2	C: fxd mica 5 pf 20% 500vdcw
C22	0130-0013		2	C: var cer 3-12 pf
C23A/B	0180-0030		2	C: fxd elect 40/120 μ f 450vdcw
C24	0150-0031		8	C: fxd ti ox 2 pf 5% 500vdcw
C25	0150-0031			C: fxd ti ox 2 pf 5% 500vdcw
*C26	0140-0024		4	C: fxd mica 2200 pf 10% 500vdcw
*C27	0140-0024			C: fxd mica 2200 pf 10% 500vdcw
C28	0150-0012			C: fxd cer 0.01 μ f 20% 1000vdcw
C29	0150-0031			C: fxd ti ox 2 pf 5% 500vdcw
C30	0150-0031			C: fxd ti ox 2 pf 5% 500vdcw
C31	0150-0031			C: fxd ti ox 2 pf 5% 500vdcw
C32	0150-0031			C: fxd ti ox 2 pf 5% 500vdcw
*C33	0140-0024			C: fxd mica 2200 pf 10% 500vdcw
*C34	0140-0024			C: fxd mica 2200 pf 10% 500vdcw
C35	0150-0012			C: fxd cer 0.01 μ f 20% 1000vdcw
C36	0150-0031			C: fxd ti ox 2 pf 5% 500vdcw
C37	0150-0031			C: fxd ti ox 2 pf 5% 500vdcw
C38	0150-0012			C: fxd cer 0.01 μ f 20% 1000vdcw
C39	0140-0004			C: fxd mica 15 pf 10% 500vdcw
C40	0140-0004			C: fxd mica 15 pf 10% 500vdcw
C41	0140-0145		2	C: fxd mica 22 pf 5% 500vdcw
C42	0140-0145			C: fxd mica 22 pf 5% 500vdcw
C43	0140-0043		2	C: fxd mica 330 pf 10% 500vdcw
C44	0131-0005		4	C: var mica 2-25 pf 175vdcw
C45	0140-0001			C: fxd mica 5 pf 20% 500vdcw
C101	0160-0001		1	C: fxd paper 0.1 μ f 10% 600vdcw
C102	0150-0015		4	C: fxd ti ox 2.2 pf 10% 500vdcw
C103	0150-0012			C: fxd cer 0.01 μ f 20% 1000vdcw
C104	0150-0015		1	C: fxd ti ox 2.2 pf 10% 500vdcw
C105	0131-0005			C: var mica 2-25 pf 175vdcw

*Optimum value selected at factory; average value shown

Table 6-2. Replaceable Parts (Cont'd)

Ref Desig	hp Part No.	RS	TQ	Description (See Table 6-1.)
C106	0131-0001		2	C: var mica 50-380 pf 175vdcw
C107	0130-0012			C: var cer 5-25 pf
C108	0150-0015			C: fxd ti ox 2.2 pf 10% 500vdcw
C109	0150-0015			C: fxd ti ox 2.2 pf 10% 500vdcw
C110	0131-0001			C: var mica 50-380 pf 175vdcw
C111	0140-0007		1	C: fxd mica 680 pf 10% 500vdcw
C112	0150-0012			C: fxd cer 0.01 μ f 20% 1000vdcw
C200	0140-0100		2	C: fxd mica 33 pf 5% 500vdcw
C201	0150-0029		1	C: fxd ti ox 1.0 pf 10% 500vdcw
C202	0160-0003		2	C: fxd paper 0.022 μ f 10% 600vdcw
C203	0140-0100			C: fxd mica 33 pf 5% 500vdcw
C204	0140-0034		1	C: fxd mica 22 pf 5% 500vdcw
C205	0180-0045		2	C: fxd elect 20 μ f 25vdcw
C206	0180-0045			C: fxd elect 20 μ f 25vdcw
C207	0140-0025		1	C: fxd mica 68 pf 10% 500vdcw
C209	0150-0023		4	C: fxd cer 0.002 μ f 20% 1000vdcw
C210	0140-0041		1	C: fxd mica 100 pf 5% 500vdcw
C211	0140-0054		1	C: fxd mica 100 pf 10% 500vdcw
C212	0150-0012			C: fxd cer 0.01 μ f 20% 1000vdcw
C213	0140-0010		1	C: fxd mica 820 pf 10% 500vdcw
C214	0131-0004		2	C: var mica 14-150 pf 175vdcw
C215	0150-0012			C: fxd cer 0.01 μ f 20% 1000vdcw
C217	0140-0032		1	C: fxd mica 47 pf 10% 500vdcw
C218	0140-0043			C: fxd mica 330 pf 10% 500vdcw
C219	0140-0035		1	C: fxd mica 39 pf 5% 500vdcw
C221	0170-0028		1	C: fxd my 0.2 μ f 5% 200vdcw
C222	0170-0027		1	C: fxd my 0.02 μ f 5% 200vdcw
C223	0131-0003		1	C: var mica 170-780 pf 175vdcw
C224	0170-0026		1	C: fxd my 0.0018 μ f 5% 200vdcw
C225	0131-0004			C: var mica 14-150 pf 175vdcw
C226	0130-0001		1	C: var cer 7-45 pf 500vdcw
C227	0160-0018		1	C: fxd paper 0.22 μ f 10% 400vdcw
C228	0160-0003			C: fxd paper 0.022 μ f 10% 600vdcw
C229	0160-0007		1	C: fxd paper 2200 pf 10% 600vdcw
C230	0140-0031		1	C: fxd mica 220 pf 10% 500vdcw
C231	0140-0055		1	C: fxd mica 150 pf 10% 500vdcw
C232	0140-0058		1	C: fxd mica 1500 pf 5% 500vdcw
C233	0131-0005			C: var mica 2-25 pf 175vdcw
C234	0140-0027		1	C: fxd mica 470 pf 10% 500vdcw
C235	0131-0005			C: var mica 2-25 pf 175vdcw
C236	0140-0105		1	C: fxd mica 30 pf 5% 500vdcw
C237	0140-0067		1	C: fxd mica 150 pf 5% 500vdcw
C300	0160-0001			C: fxd paper 0.1 μ f 10% 600vdcw
C301	0150-0023			C: fxd cer 0.002 μ f 20% 1000vdcw
C302	0140-0016		1	C: fxd mica 390 pf 5% 500vdcw
C304	0140-0004			C: fxd mica 15 pf 10% 500vdcw
C305	0160-0054		1	C: fxd my 0.01 μ f 20% 400vdcw

Table 6-2. Replaceable Parts (Cont'd)

Ref Desig	hp Part No.	RS	TQ	Description (See Table 6-1.)
C306	0160-0151		7	C: fxd cer 4700 pf 20% 4000vdcw
C307	0160-0151			C: fxd cer 4700 pf 20% 4000vdcw
C308	0150-0012			C: fxd cer 0.01 μ f 20% 1000vdcw
C309	0160-0151			C: fxd cer 4700 pf 20% 4000vdcw
C310	0160-0151			C: fxd cer 4700 pf 20% 4000vdcw
C311	0170-0003		1	C: fxd my 0.051 μ f 10% 200vdcw
C312	0160-0151			C: fxd cer 4700 pf 20% 4000vdcw
C313	0150-0023			C: fxd cer 0.002 μ f 20% 1000vdcw
C314	0160-0151			C: fxd cer 4700 pf 20% 4000vdcw
C315	0160-0151			C: fxd cer 4700 pf 20% 4000vdcw
C321	0180-0042		1	C: fxd elect 120 μ f 350vdcw
C322A/E	0180-0030			C: fxd elect 40/120 μ f 450vdcw
C323	0150-0012			C: fxd cer 0.01 μ f 20% 1000vdcw
C324	0180-0024		1	C: fxd elect 40 μ f 450vdcw
C325A/E	0180-0012		1	C: fxd elect 20/20 μ f 450vdcw
C327	0150-0012			C: fxd cer 0.01 μ f 20% 1000vdcw
C329	0160-0013		1	C: fxd paper 0.1 μ f 10% 400vdcw
C330	0150-0012			C: fxd cer 0.01 μ f 20% 1000vdcw
C332	0180-0056		1	C: fxd elect 1000 μ f 50vdcw
C334	0150-0023			C: fxd cer 0.002 μ f 20% 1000vdcw
C335	0150-0024		1	C: fxd cer 0.01 μ f 10% 600vdcw
CR202	1901-0044		1	CR: si
CR301	1901-0045		1	CR: si
CR302	1901-0028		6	CR: si
CR303	1901-0028			CR: si
CR304	1901-0028			CR: si
CR305	1901-0028			CR: si
CR306	1901-0028			CR: si
CR307	1901-0028			CR: si
CR308	1902-3256		1	CR: si, breakdown 23.7 v 5%
DS301	2140-0012		1	DS: incd 6-8v 2-pin base
F301	2110-0006		1	F: cartridge 2a (115 v operation)
	2110-0007		1	F: cartridge 1a (230 v operation)
J1	5060-0626			J: assembly, consisting of
	0340-0090		1	Insulator: 2-hole front
	0340-0086		1	Insulator: 2-hole rear
	1510-0007		2	Binding post: insulated red
	5060-0625		1	Binding post: insulated black w/shorting link
J2	5060-0626			J: assembly, consisting of:
	0340-0091		1	Insulator: 3-hole front
	0340-0087		1	Insulator: 3-hole rear
	1510-0007		2	Binding post: insulated red
	5060-0626		1	Binding post: insulated black w/shorting link
J101				J: assembly, consisting of:
	0340-0089		2	Insulator: single front or rear
	1510-0007		1	Binding post: insulated red
	1510-0006		1	Binding post: insulated black

Table 6-2. Replaceable Parts (Cont'd)

Ref Desig	hp Part No.	RS	TQ	Description (See Table 6-1.)
L201	9140-0022		1	L: fxd rf 500 μ h
L301	9140-0019		1	L: fxd rf 200 μ h
L302	5060-0409		1	L: trace alignment
P301	8120-0050		1	Power cable assy
Q301	1850-0038		1	Q: si pnp 2N301
R1	0727-0274		2	R: fxd car flm 1 megohm 1% 1/2w
R2	0686-1055		3	R: fxd comp 1 megohm 5% 1/2w
R3	0727-0259		2	R: fxd car flm 900k ohms 1% 1/2w
R4	0727-0210		2	R: fxd car flm 111k ohms 1% 1/2w
R5	0727-0269		2	R: fxd car flm 990k ohms 1% 1/2w
R6	0727-0153		2	R: fxd car flm 9100 ohms 1% 1/2w
R7	0727-0100		2	R: fxd car flm 1000 ohms 1% 1/2w
R8	0687-1041		3	R: fxd comp 100k ohms 10% 1/2w
R9	0727-0274			R: fxd car flm 1 megohm 1% 1/2w
R10	0686-1055			R: fxd comp 1 megohm 5% 1/2w
R11	0727-0259			R: fxd car flm 900k ohms 1% 1/2w
R12	0727-0210			R: fxd car flm 111k ohms 1% 1/2w
R13	0727-0269			R: fxd car flm 990k ohms 1% 1/2w
R14	0727-0153			R: fxd car flm 9100 ohms 1% 1/2w
R15	0727-0100			R: fxd car flm 1000 ohms 1% 1/2w
R16	0687-1041			R: fxd comp 100k ohms 10% 1/2w
R17	0687-1011	15		R: fxd comp 100 ohms 10% 1/2w
R18	0687-1011			R: fxd comp 100 ohms 10% 1/2w
R19	0687-4711	3		R: fxd comp 470 ohms 10% 1/2w
R20	0727-0197	4		R: fxd car flm 59.48k ohms 1% 1/2w
R21	0727-0197			R: fxd car flm 59.48k ohms 1% 1/2w
R22	0730-0062	2		R: fxd car flm 80k ohms 1% 1w
R23	2100-0019	2		R: var comp 500 ohms 10%
R24	2100-0186	2		R: var comp 250k ohms 20% 1/4w
R25	0687-1021	6		R: fxd comp 1000 ohms 10% 1/2w
R26	0687-1831	4		R: fxd comp 18k ohms 10% 1/2w
R27	2100-0175	2		R: var comp 250k ohms 20% 1/4w
R28	0687-1011			R: fxd comp 100 ohms 10% 1/2w
R29	0687-1011			R: fxd comp 100 ohms 10% 1/2w
R30	0730-0025	2		R: fxd car flm 8700 ohms 1% 1w
R31	2100-0202	1		R: var comp 500 ohms 10% 1/2w
R32	0730-0068	4		R: fxd car flm 98k ohms 1% 1w
R33	0730-0068			R: fxd car flm 98k ohms 1% 1w
R34	0686-1635	4		R: fxd comp 16k ohms 5% 1/2w
R35	0686-1635			R: fxd comp 16k ohms 5% 1/2w
R36	0687-1011			R: fxd comp 100 ohms 10% 1/2w
R37	0687-1011			R: fxd comp 100 ohms 10% 1/2w
R38	0692-2235	2		R: fxd comp 22k ohms 5% 2w
R39	0690-8221	2		R: fxd comp 8200 ohms 10% 1w
R40	0727-0197			R: fxd car flm 59.48k ohms 1% 1/2w
R41	0727-0197			R: fxd car flm 59.48k ohms 1% 1/2w
R42	0730-0062			R: fxd car flm 80k ohms 1% 1w
R43	2100-0019			R: var comp 500 ohms 10%
R44	2100-0186			R: var comp 250k ohms 20% 1/4w
R45	0687-1021			R: fxd comp 1000 ohms 10% 1/2w

Table 6-2. Replaceable Parts (Cont'd)

Ref Desig	hp Part No.	RS	TQ	Description (See Table 6-1.)
R46	0687-1831			R: fxd comp 18k ohms 10% 1/2w
R47	2100-0175			R: var comp 250k ohms 20% 1/4w
R48	0687-1011			R: fxd comp 100 ohms 10% 1/2w
R49	0687-1011			R: fxd comp 100 ohms 10% 1/2w
R50	0730-0068			R: fxd car flm 98k ohms 1% 1w
R51	0730-0068			R: fxd car flm 98k ohms 1% 1w
R52	0730-0025			R: fxd car flm 8700 ohms 1% 1w
R54	0686-1635			R: fxd comp 16k ohms 5% 1/2w
R55	0686-1635			R: fxd comp 16k ohms 5% 1/2w
R56	0687-1011			R: fxd comp 100 ohms 10% 1/2w
R57	0687-1011			R: fxd comp 100 ohms 10% 1/2w
R58	0690-8221			R: fxd comp 8200 ohms 10% 1w
R59	0692-2235			R: fxd comp 22k ohms 5% 2w
R60	0693-1831	4		R: fxd comp 18k ohms 10% 2w
R61	0693-4731	1		R: fxd comp 47k ohms 10% 2w
R62	0689-2435	4		R: fxd comp 24k ohms 5% 1w
R63	0689-2435			R: fxd comp 24k ohms 5% 1w
R64	0727-0279	2		R: fxd car flm 1. 15 megohms 1% 1/2w
R65	0727-0279			R: fxd car flm 1. 15 megohms 1% 1/2w
R66	0727-0287	3		R: fxd car flm 2 megohms 1% 1/2w
R67	0727-0287			R: fxd car flm 2 megohms 1% 1/2w
R68	0687-2741	2		R: fxd comp 270k ohms 10% 1/2w
R69	0687-5641	1		R: fxd comp 560k ohms 10% 1/2w
R70	0687-1551	3		R: fxd comp 1. 5 megohms 10% 1/2w
R71	0687-5631	1		R: fxd comp 56k ohms 10% 1/2w
R101	2100-0015	2		R: var comp 500k ohms
R102	0687-1241	1		R: fxd comp 120k ohms 10% 1/2w
R103	0687-1051	9		R: fxd comp 1 megohm 10% 1/2w
R104	0687-1041			R: fxd comp 100k ohms 10% 1/2w
R105	0687-1011			R: fxd comp 100 ohms 10% 1/2w
R106	0687-2231	2		R: fxd comp 22k ohms 10% 1/2w
R107	2100-0192	3		R: var comp 50k ohms 20% 1/3w
R108	2100-0193	1		R: var comp 5000 ohms 20% 1/2w
R109	0687-2721	1		R: fxd comp 2700 ohms 10% 1/2w
R110	2100-0190	2		R: var comp 2500 ohms 20% 1/2w
R111	0687-1231	2		R: fxd comp 12k ohms 10% 1/2w
R112	0690-1041	3		R: fxd comp 100k ohms 10% 1w
R113	2100-0173	1		R: var comp conc 50k ohms front; 100k ohms rear 20% w/dpst S (includes R257)
R114	2100-0190			R: var comp 2500 ohms 20% 1/2w
R115	0690-1041			R: fxd comp 100k ohms 10% 1w
R116	0687-1231			R: fxd comp 12k ohms 10% 1/2w
R117	0687-1011			R: fxd comp 100 ohms 10% 1/2w
R118	0687-1011			R: fxd comp 100 ohms 10% 1/2w
R119	0692-3635	2		R: fxd comp 36k ohms 5% 2w
R120	0687-6821	2		R: fxd comp 6800 ohms 10% 1/2w
*R121	0693-1031	2		R: fxd comp 10k ohms 10% 2w
R122	0686-2425	1		R: fxd comp 2400 ohms 5% 1/2w
R123	0687-6821			R: fxd comp 6800 ohms 10% 1/2w
R124	0692-3635			R: fxd comp 36k ohms 5% 2w

*Optimum value selected at factory; average value shown

Table 6-2. Replaceable Parts (Cont'd)

Ref Desig	hp Part No.	RS	TQ	Description (See Table 6-1.)
R200	0687-1021			R: fxd comp 1000 ohms 10% 1/2w
R201	0687-1051			R: fxd comp 1 megohm 10% 1/2w
R202	0687-1011			R: fxd comp 100 ohms 10% 1/2w
R203	0687-1051			R: fxd comp 1 megohm 10% 1/2w
R204	0686-3925		1	R: fxd comp 3900 ohms 5% 1/2w
R205	0727-0202		1	R: fxd car flm 83k ohms 1% 1/2w
R206	0686-3625		1	R: fxd comp 3600 ohms 5% 1/2w
R207	0687-1031		1	R: fxd car flm 10k ohms 10% 1/2w
R208	0689-2435			R: fxd comp 24k ohms 5% 1w
R209	0686-1045		1	R: fxd comp 100k ohms 5% 1/2w
R210	2100-0188		1	R: var comp 200k ohms 20% 1/4w (includes S202)
R211	0686-1245		2	R: fxd comp 120k ohms 20% 1/2w
R212	0727-0201		1	R: fxd car flm 71.56k ohms 1% 1/2w
R213	0686-1245			R: fxd comp 120k ohms 20% 1/2w
R214	0687-6831		1	R: fxd comp 68k ohms 10% 1/2w
R216	0687-1831			R: fxd comp 18k ohms 10% 1/2w
R217	0687-1011			R: fxd comp 100 ohms 10% 1/2w
R221	0690-1041			R: fxd comp 100k ohms 10% 1w
R223	0687-1021			R: fxd comp 1000 ohms 10% 1/2w
R224	0687-2731		6	R: fxd comp 27k ohms 10% 1/2w
R225	0687-6841		3	R: fxd comp 680k ohms 10% 1/2w
R226	0693-1831			R: fxd comp 18k ohms 10% 2w
R227	0687-2731			R: fxd comp 27k ohms 10% 1/2w
R228	2100-0260		1	R: var comp 20k ohms 20% 1/3w
R229	0687-2731			R: fxd comp 27k ohms 10% 1/2w
R230	0686-4345		1	R: fxd comp 430k ohms 5% 1/2w
R231	2100-0191		1	R: var comp 250k ohms 20% 1/4w
*R232	0687-2241		2	R: fxd comp 220k ohms 10% 1/2w
*R233	0687-2241			R: fxd comp 220k ohms 10% 1/2w
R234	0771-0006		1	R: fxd metflm 27k ohms 10% 4w
R235	0686-2435		1	R: fxd comp 24k ohms 5% 1/2w
R236	0686-1645		1	R: fxd comp 160k ohms 5% 1/2w
R237	0686-1055			R: fxd comp 1 megohm 5% 1/2w
R238	0686-2055		1	R: fxd comp 2 megohms 5% 1/2w
R239	0687-4711			R: fxd comp 470 ohms 10% 1/2w
R240	0687-2731			R: fxd comp 27k ohms 10% 1/2w
R241	0693-1041		1	R: fxd comp 100k ohms 10% 2w
R242	0687-8241		2	R: fxd comp 820k ohms 10% 1/2w
R243	0687-4711			R: fxd comp 470 ohms 10% 1/2w
R247	2100-0194		1	R: var comp 1000 ohms 20% 1/2w
R248	0689-2435			R: fxd comp 24k ohms 5% 1w
R249	0686-5635		1	R: fxd comp 5600 ohms 5% 1/2w
R250	0687-3921		1	R: fxd comp 3900 ohms 10% 1/2w
R251	2100-0192			R: var comp 50k ohms 20% 1/3w
R252	0687-2231			R: fxd comp 22k ohms 10% 1/2w
*R253	0687-6841			R: fxd comp 680k ohms 10% 1/2w
R254A	0727-0292		4	R: fxd car flm 3 megohms 1% 1w
R254B	0727-0292			R: fxd car flm 3 megohms 1% 1w
R255	0727-0292			R: fxd car flm 3 megohms 1% 1w

*Optimum value selected at factory; average value shown.

Table 6-2. Replaceable Parts (Cont'd)

Ref Desig	hp Part No.	RS	TQ	Description (See Table 6-1.)
R256	0727-0292			R: fxd car flm 3 megohms 1% 1w
R257				NSR: p/o R113
R258	0687-3931	1		R: fxd comp 39k ohms 10% 1/2w
R259	0687-2741			R: fxd comp 270k ohms 10% 1/2w
R260	0727-0173	1		R: fxd car flm 20k ohms 1% 1/2w
R261	0727-0287			R: fxd car flm 2 megohms 1% 1/2w
R262	0727-0221	1		R: fxd car flm 200k ohms 1% 1/2w
R263	0727-0285	1		R: fxd car flm 1.8 megohms 1% 1/2w
R300	0690-1021	1		R: fxd comp 1000 ohms 10% 1w
R301	0687-1021			R: fxd comp 1000 ohms 10% 1/2w
R302	0687-4731	4		R: fxd comp 47k ohms 10% 1/2w
R303	0693-1541	1		R: fxd comp 150k ohms 10% 1w
R304	0690-5641	2		R: fxd comp 560k ohms 10% 1w
R305	0687-1051			R: fxd comp 1 megohm 10% 1/2w
R306	0687-1551			R: fxd comp 1.5 megohms 10% 1/2w
R307	0686-3055	1		R: fxd comp 3 megohms 5% 1/2w
R308	2100-0074	1		R: var comp 1 megohm 30% 1/4w
R309	0693-4751	1		R: fxd comp 4.7 megohms 10% 2w
R310	0693-5651			R: fxd comp 5.6 megohms 10% 2w
R311	0693-5651			R: fxd comp 5.6 megohms 10% 2w
R312	2100-0105	1		R: var comp 3.5 megohms 30% 1/2w
*R313	0687-6841			R: fxd comp 680k ohms 10% 1/2w
R314	0687-2731			R: fxd comp 27k ohms 10% 1/2w
R315	0687-2731			R: fxd comp 27k ohms 10% 1/2w
R316	2100-0192			R: var comp 50k ohms 20% 1/3w
R317	0690-5631	1		R: fxd comp 56k ohms 10% 1w
R318	0687-2251	1		R: fxd comp 2.2 megohms 10% 1/2w
R319	0693-8251	3		R: fxd comp 8.2 megohms 10% 2w
R320	0693-8251			R: fxd comp 8.2 megohms 10% 2w
R321	0693-8251			R: fxd comp 8.2 megohms 10% 2w
R322	2100-0015			R: var comp 500k ohms
R323	2100-0171	1		R: var comp 200k ohms 20% 1/4w (includes S301)
R324	0687-4731			R: fxd comp 47k ohms 10% 1/2w
R325	0687-1551			R: fxd comp 1.5 megohms 10% 1/2w
R327	0687-1021			R: fxd comp 1000 ohms 10% 1/2w
R328	0687-4731			R: fxd comp 47k ohms 10% 1/2w
R331	0687-1051			R: fxd comp 1 megohm 10% 1/2w
R332	0687-1051			R: fxd comp 1 megohm 10% 1/2w
R333	0690-5641			R: fxd comp 560k ohms 10% 1w
R334	0690-4741	1		R: fxd comp 470k ohms 10% 1w
R335	0687-4731			R: fxd comp 47k ohms 10% 1/2w
R336	0687-1051			R: fxd comp 1 megohm 10% 1/2w
R337	0819-0024	1		R: fxd ww 4000 ohms 20w
*R338	0727-0240	1		R: fxd car flm 405k ohms 1% 1/2w
*R339	0727-0216	1		R: fxd car flm 136.7k ohms 1% 1/2w
R340	0727-0221			R: fxd car flm 200k ohms 1% 1/2w
R341	0687-2261	1		R: fxd comp 22 megohms 10% 1/2w
*R342	0693-1031			R: fxd comp 10k ohms 10% 2w
R343	0727-0286	1		R: fxd car flm 1.88 megohms 1% 1/2w
R344	2100-0189	2		R: var comp 1 megohm 30% 1/4w
R345	0727-0289	2		R: fxd car flm 2.52 megohms 1% 1/2w

*Optimum value selected at factory; average value shown.

Table 6-2. Replaceable Parts (Cont'd)

Ref Desig	hp Part No.	RS	TQ	Description (See Table 6-1.)
R346	0687-8241			R: fxd comp 820k ohms 10% 1/2w
R347	0687-8231		1	R: fxd comp 82k ohms 10% 1/2w
R348A	0693-1831			R: fxd comp 18k ohms 10% 2w
R348B	0693-1831			R: fxd comp 18k ohms 10% 2w
R350	0687-1831			R: fxd comp 18k ohms 10% 1/2w
R351	0687-1531		1	R: fxd comp 15k ohms 10% 1/2w
R352	0687-1051			R: fxd comp 1 megohm 10% 1/2w
R353	0811-1556		1	R: fxd ww 2.7 ohms 10% 2w
R355	0767-0009		1	R: fxd car film 12k ohms 5% 3w
R356	2100-0189			R: var comp 1 megohm 31% 1/4w
R357	0727-0289			R: fxd car film 2.52 megohms 1% 1/2w
R358	0686-2455		1	R: fxd comp 2.4 megohms 5% 1/2w
R359	0727-0077		1	R: fxd car film 500 ohms 1% 1/2w
R360A	0687-2711		2	R: fxd comp 270 ohms 10% 1/2w
R360B	0687-2711			R: fxd comp 270 ohms 10% 1/2w
R361				See Option 05
R362	0687-1051			R: fxd comp 1 megohm 10% 1/2w
R363	0687-4741		1	R: fxd comp 470k ohms 10% 1/2w
R364	0686-9115		1	R: fxd comp 910 ohms 5% 1/2w
R365	2100-0049		1	R: var comp 2-sec 20k ohms 10% 2w
S1	122A-19D		2	S: vert atten assy complete
S2	122A-19D			S: vert atten assy complete
S3	122A-19B		1	S: presentation-po assy complete
S101	3101-0001		1	S: toggle spst
S102	3101-0002		1	S: toggle spdt
S103				NSR: p/o S204
S201	122A-19C		1	S: sync-trig level assy complete
S202				NSR: p/o R210
S204	122A-19A		1	S: swp t-horiz sens assy complete (includes S103)
S301				NSR: p/o R323
T301	120A-11A-1		1	T: hv
T302	9100-1102		1	T: power
V1	5080-0425		5	V: 12AU7
V2	5080-0425			V: 12AU7
V3	5080-0411		3	V: 6DJ8/ECC88
V4	5080-0425			V: 12AU7
V5	5080-0425			V: 12AU7
V6	5080-0411			V: 6DJ8/ECC88
V7	1932-0022		1	V: 6DJ8/ECC88
V8	5080-0425			V: 12AU7
V9	1923-0021		2	V: 6AU6
V10	2140-0008		6	V: ne 1/25w type NE 2
V11	2140-0008			V: ne 1/25w type NE 2
V101	5080-0411			V: 6DJ8/ECC88
V102	5080-0405		1	V: 12AT7
V201	5080-0412		1	V: 6AN8
V202	1933-0014		3	V: 6GH8A

Table 6-2. Replaceable Parts (Cont'd)

Ref Desig	hp Part No.	RS	TQ	Description (See Table 6-1.)
V203	1932-0029		2	V: 12AU7
V204	1921-0005		1	V: 6C4
V205	1933-0014			V: 6GH8A
V210	2140-0084		6	V: ne aged and sel green code
V211	2140-0084			V: ne aged and sel green code
V212	2140-0008			V: ne 1/25w type NE 2
V213	2140-0084			V: ne aged and sel green code
V214	2140-0084			V: ne aged and sel green code
V301	1932-0029			V: 12AU7
V302	1923-0018		1	V: 6AQ5
V303	1920-0001		2	V: 5642
V304	1920-0001			V: 5642
V305	5083-0053		1	V: crt int graticule P31 phosphor
	5083-0032			V: crt int graticule P2 phosphor
	5083-0033			V: crt int graticule P7 phosphor
	5083-0042			V: crt int graticule P11 phosphor
V306	1921-0010		2	V: 12B4A
V307	1933-0014			V: 6GH8A
V308	1921-0010			V: 12B4A
V309	1923-0021			V: 6AU6
V310	1940-0001		1	V: 5651
V315	2140-0008			V: ne 1/25w type NE 2
V316	2140-0084			V: ne aged and sel green code
V317	2140-0084			V: ne aged and sel green code
V321	2140-0008			V: ne 1/25w type NE 2
V322	2140-0008			V: ne 1/25w type NE 2
				MISCELLANEOUS
	0370-0026		3	Knob: horiz pos; focus; intensity (Model 122AR only)
			2	focus; intensity (Model 122A only)
	0370-0027		1	Knob: chan A polarity
	0370-0029		1	Knob: horiz pos (Model 122A)
	0370-0037		5	Knob: A vert sens; Bvert sens; sweep time-horiz sens; vert presentation; sync
	0370-0062		4	Knob: trigger level, A vert sens; B vert sens; sweep time-horiz sens
	0370-0064		1	Knob: Bvert pos
	0370-0067		1	Knob: A vert pos
	1205-0003		1	Bushing: insulator u/w CR308
	1205-0007		1	Nut: heat dissipator u/w CR308
	1205-0008		1	Body: heat dissipator u/w CR308
	1400-0084		1	Fuse holder
	1450-0020		1	Jewel: pilot lamp
	1450-0022		1	Lamp holder

SECTION VII MANUAL CHANGES AND OPTIONS

7-1. MANUAL CHANGES.

7-2. This manual applies to standard hp Model 122A and Model 122AR Oscilloscopes having a serial number prefixed by 521-. The following paragraphs provide instructions for modifying this manual to cover older or newer instruments. Refer to the separate "Manual Changes" sheet supplied with this manual for Errata.

7-3. OLDER INSTRUMENTS.

7-4. Table 7-1 contains information on changes required to adapt this manual to an older instrument (lower serial prefix). Check Table 7-1 for your instrument serial prefix and make the changes indicated. Note that these changes adapt the manual to cover a particular instrument as manufactured and therefore will not apply to an instrument subsequently modified in the field.

Table 7-1. Manual Changes

Instrument Serial Prefix or Number	Incorporate Change Number(s)
Prefix 501-	1
Prefix 436-	1, 2
Prefix 425-, 333-, 320-	1 thru 3
Prefix 141-	1 thru 4
Prefix 037-	1 thru 5
Prefix 006-	1 thru 6
Number 752 thru 1449	1 thru 6
Number 651 thru 751	1 thru 7
Number 251 thru 650	1 thru 8
Number 101 thru 250	1 thru 9

CHANGE 1

Table 6-2,

R353: Information given in manual is preferred replacement on all Model 122A/AR's.

T302: Change to hp Part No. 9100-0105; same description; Mfr hp.

CHANGE 2

Table 6-2,

C306, C309: Change to hp Part No. 0160-0046; C: fxd, paper, 3300 pf, 20%, 6000vdcw; Mfr 56289; Mfr Part No. 184P332060.

C307, C310: Change to hp Part No. 0160-0061; C: fxd, paper, 1500 pf, 20%, 5000vdcw; Mfr 56289; Mfr Part No. 184P152020.

C312: Change to hp Part No. 0160-0062; C: fxd, paper, 0.015 μ f, 10%, 3000vdcw; Mfr 56289; Mfr Part No. 184P153930.

C314, C315: Delete.

Figure 8-8, High Voltage Power Supply Schematic,

C306, C309: Change value to 3300 pf.

C307, C310: Change value to 1500 pf.

C312: Change value to .015 μ f.

C314, C315: Delete.

CHANGE 3

Table 6-2,

CR308: Change to hp Part No. 1902-0165; same description; Mfr hp.

Under MISCELLANEOUS: Delete entries for hp Part No's. 1205-0003, 1205-0007, and 1205-0008.

CHANGE 4

Sections I, II, III, V, VI, and VIII: references in text and illustrations to SCALE control apply to instruments having an internal graticule CRT. To adapt this manual to cover instruments with an external graticule CRT, refer to Option 05 in Paragraph 7-10.

CHANGE 5

Table 6-2,

CR302 thru CR307: Change to hp Part No. 1901-0007; CR: si, 500 ma, 400 piv; Mfr hp.

R119, R124: Change to hp Part No. 0692-3035; R: fxd comp, 30k ohms, 5%, 2w; Mfr hp.

R122: Change to hp Part No. 0687-1821; R: fxd, comp, 1800 ohms, 10%, 1/2w; Mfr hp.

R337: Change to hp Part No. 0819-0013; R: fxd, ww, 3500 ohms, 10%, 20w; Mfr hp.

CHANGE 6

Table 6-2,

C335: Change to hp Part No. 0150-0012; C: fxd, cer, 0.01 μ f, 20%, 1000vdcw; Mfr 56289; Mfr Part No. CD4-53050.

R228: Change to hp Part No. 2100-0187; R: var, comp, 10k ohms, 30%, 1/2w; Mfr hp.

R249: Change to hp Part No. 0686-2745; R: fxd, comp, 270k ohms, 5%, 1/2w; Mfr hp.

Figure 8-6,

R228: Change value to 10k ohms.

R249: Change value to 270k ohms; connect end opposite switch to ground instead of junction of R209 and R210.

V204: Change plate connection (pins 1 and 5) to CR202 cathode.

Figure 8-9,

C335: Change value to 0.01 μ f.

CHANGE 7

Table 6-2,

C219: Delete.

Figure 8-6,

C219: Delete.

CHANGE 8

Table 6-2,

P301: Change to hp Part No. 8120-0015; same description; Mfr hp.

R121: Change to hp Part No. 0693-6821; R: fxd, comp, 6800 ohms, 10%, 2w; Mfr hp.

CHANGE 8 (Cont'd)

- R253: Change to hp Part No. 0690-4731; R: fxd, comp, 47k ohms, 10%, 1w; Mfr hp.
- R360A, B: Change to R360; hp Part No. 2100-0078; R: var, comp, 500 ohms, 30%, 0.3w; Mfr hp.
- V204: Change to hp Part No. 1932-0039; V: 12AU7; Mfr 80131; Mfr Part No. 12AU7.
- Add V215, V216, V217: hp Part No. 2140-0083; V: ne aged and selected blue code; Mfr 74276; Mfr Part No. A091.

Figure 8-6,

- CR202: Change to V204A, 1/2 of 12AU7 tube; plate pin 6 and grid pin 7 connect common to junction of C18, R200, and R223; cathode pin 8 connects same as replaced CR202 cathode.
- R121: Change to 6800 ohms.
- V204: Change to V204B, 1/2 of 12AU7 tube; plate pin 1, grid pin 2, and cathode pin 3.
- Add V215, V216, V217: Connect neon bulbs in series between input end of R243 and pin 6 of V205B.

Figure 8-7,

- R253: Change value to 47k ohms.

Figure 8-9,

- R360A, B: Replace with one 500 ohm variable resistor; variable arm connects to -30 v. Label "Hum Balance".

CHANGE 9

Table 6-2,

- C29, C30, C36, C37: Change to hp Part No. 0150-0011; C: fxd, ti ox, 1.5 pf, 20%, 500vdcw; Mfr 78488; Mfr Part No. Type GA.

Figure 8-3,

- C29, C30, C36, C37: Change value to 1.5 pf.

7-5. NEWER INSTRUMENTS.

7-6. As changes are made to the Model 122A/AR Oscilloscope, newer instruments may have serial prefixes higher than 521-. The manual for these instruments will be supplied with a "Manual Changes" sheet which contains the required updating information. If the change sheet is missing, contact the nearest Hewlett-Packard Sales/Service Office.

7-7. OPTIONS.

7-8. Options for a hp instrument are factory-installed standard modifications to the standard instrument. Two options, covered in Paragraphs 7-9 and 7-11, are currently offered for the Model 122A/AR. For information on other options which may be available at a later date, contact the nearest Hewlett-Packard Sales/Service Office. Also, see Paragraph 7-13 for information about special order instruments.

7-9. OPTION 05.

7-10. Option 05 on the Model 122A/AR consists of an external graticule CRT with related circuitry for the graticule lighting. (Option 05 is the same as standard instruments with a serial prefix of 141- and below.) For instruments equipped with Option 05, make the following changes in this manual.

Table 6-2,

- Add DS302, DS303, DS304, DS404: hp Part No. 2140-0009; Lamp; incandescent, 6-8w; 0.15 amp; Mfr 24455; Mfr Part No. #47.

- Add R361: hp Part No. 2100-0140; R: var, ww, 25 ohms, 10%, 2w (includes S303); Mfr hp.
- Add S303: NSR, part of R361.
- V305: Change to hp Part No. 5083-0010 for P1 phosphor (5083-0020 for P2; 5083-0030 for P7; 5083-0041 for P11); CRT external graticule. Mfr hp.

Figure 8-9, Low Voltage, Filament Supplies, and Calibrator Schematic,

- L302: Delete.
- R364, R365: Delete.

Add graticule lighting circuit in Figure 7-1.

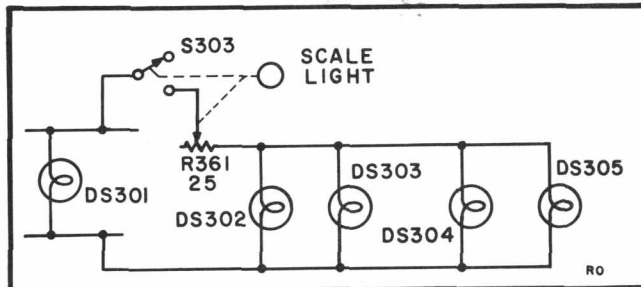

Figure 7-1. Option 05 Graticule Lighting Schematic

7-11. OPTION 06.

7-12. Option 06 on the Model 122A/AR consists of three connectors added on the rear panel of the instrument. This provides an input connection in parallel with front panel Channel A and Channel B vertical input connectors and with the EXT horizontal input connector. The specification on input impedance for the Vertical Amplifier is changed to "1 megohm, approximately 100 pf shunt capacitance." Mating connectors and cable clamps are supplied with the option. Make the following additions to the standard manual:

Table 6-2,

- Add: Type MS-3102A-10SL-3P male connector; hp Part No. 1251-0039.
- Add: Type MS-3106A-10SL-3S female connector; hp Part No. 1251-0038.
- Add: Type AN-3057-4 cable clamp; hp Part No. 1251-0040.

Figure 8-4,

- Add: Parallel connector with J1 and J2. Pin A is connected to the upper binding post (red); pin B is connected to the center binding post (red); pin C is connected to chassis ground.

Figure 8-5,

- Add: Parallel connector with J101. Pin A is connected to the upper binding post (red); pins B and C are connected to chassis ground.

7-13. SPECIAL INSTRUMENTS.

7-14. Modified versions (per customer's specifications) of any hp instrument are available on special order. The manual for these special instruments (having electrical modifications) includes separate insert sheets, which describe the modification and any manual changes required, in addition to any possible "Manual Changes" sheet (refer to Paragraph 7-6). Contact the nearest hp Sales/Service Office if either of these sheets is missing from the manual for a special instrument, being sure to refer to the instrument by its full specification number and name.

SECTION VIII

SCHEMATIC DIAGRAMS

8-1. SCHEMATIC DIAGRAMS.

8-2. GENERAL NOTES.

8-3. The schematic diagrams, Figures 8-3 through 8-9, are in this section of the manual. They are drawn to show the electronic function of the circuitry and the circuits shown on one schematic may include all or part of several different functional areas. Generally, the schematics cover the Vertical Amplifiers and their input switching, the Horizontal Amplifier, the Sweep Generator and its time switching, the High Voltage Power Supply, and the Low Voltage and Filament Power Supply. Figures 8-1 and 8-2 are included to indicate the normal voltage and resistance values to be found at tube socket pins, as an aid to troubleshooting. Adjustable components are identified and located in Figures 5-1, 5-2, and 8-2. Waveforms are indicated on the schematics near the point where they may be measured and observed on a separate oscilloscope, if required.

- a. Heavy solid lines in the schematic show main signal paths.
- b. Heavy dashed lines show control, secondary signal, or feedback paths.
- c. Heavy boxed callouts indicate front panel labeled controls.
- d. Light boxed callouts indicate chassis markings.
- e. Arrows on potentiometers indicate clockwise rotation as viewed from the round shaft end.
- f. Resistance values in ohms, inductance in microhenries and capacitance in picofarads, unless otherwise specified.

8-4. VOLTAGE AND RESISTANCE DIAGRAM NOTES.

a. Each tube socket terminal is numbered and lettered to indicate the tube element and pin number, as follows:

* = no tube element	T = target (plate)
H = heater	R = reflector repeller
K = cathode	A = anode (plate)
G = control grid	S = spade
Sc = screen grid	Sh = shield
Sp = suppressor grid	NC = no external connection to socket
Hm = heater mid-tap	Δ = indefinite reading due to circuit (see b)
IS = internal shield	
P = plate	

The numerical subscript to tube-element designators indicates the section of a multiple-section tube; the letter subscript to tube-element designators indicates the functional difference between like elements in the

same tube section, such as t for triode and p for pentode. A socket terminal with an asterisk may be used as a tie point and may have a voltage and resistance shown.

b. Voltage values shown are for guidance; values may vary from these shown due to tube aging or normal differences between instruments. Resistance values may vary considerably from those shown when the circuit contains potentiometers, crystal diodes, or electrolytic capacitors.

c. Voltage measured at the terminal is shown above the line, resistance below the line. Measurements are made with a vtvm from terminal to chassis ground unless otherwise noted.

d. A solid line between socket terminals indicates a connection external to the tube between the terminals; a dotted line between terminals indicates a connection inside the tube. Voltage and resistance are given at only one of the two joined terminals.

8-5. REMOVING THE CHASSIS.

8-6. Disconnect the power cable and remove two large screws on the rear of the cabinet (Model 122A) and slide the chassis forward out of the cabinet. Access to the chassis (Model 122AR) may be gained top and/or bottom by removal of four screws.

WARNING

If the instrument is operated with the cabinet removed, dangerous voltages are exposed. Take adequate safety precautions, especially when working around the cathode-ray tube terminals and the power supplies.

8-7. TUBE REPLACEMENT.

8-8. In many cases an instrument malfunction can be corrected by replacing a weak or defective tube. Before changing the setting of any internal adjustment, check the tubes. Adjustments that are made in an attempt to compensate for a defective tube will often complicate the repair problem. It is a good practice to check tubes and instrument performance by substitution rather than by use of a "tube checker". The results obtained from the "tube checker" can be misleading. Before removing a tube, mark it so that if the tube is good it can be returned to the same socket. Replace only those tubes proved to be weak or defective. Any tube with corresponding standard EIA (JEDEC) designations can be used for replacement.

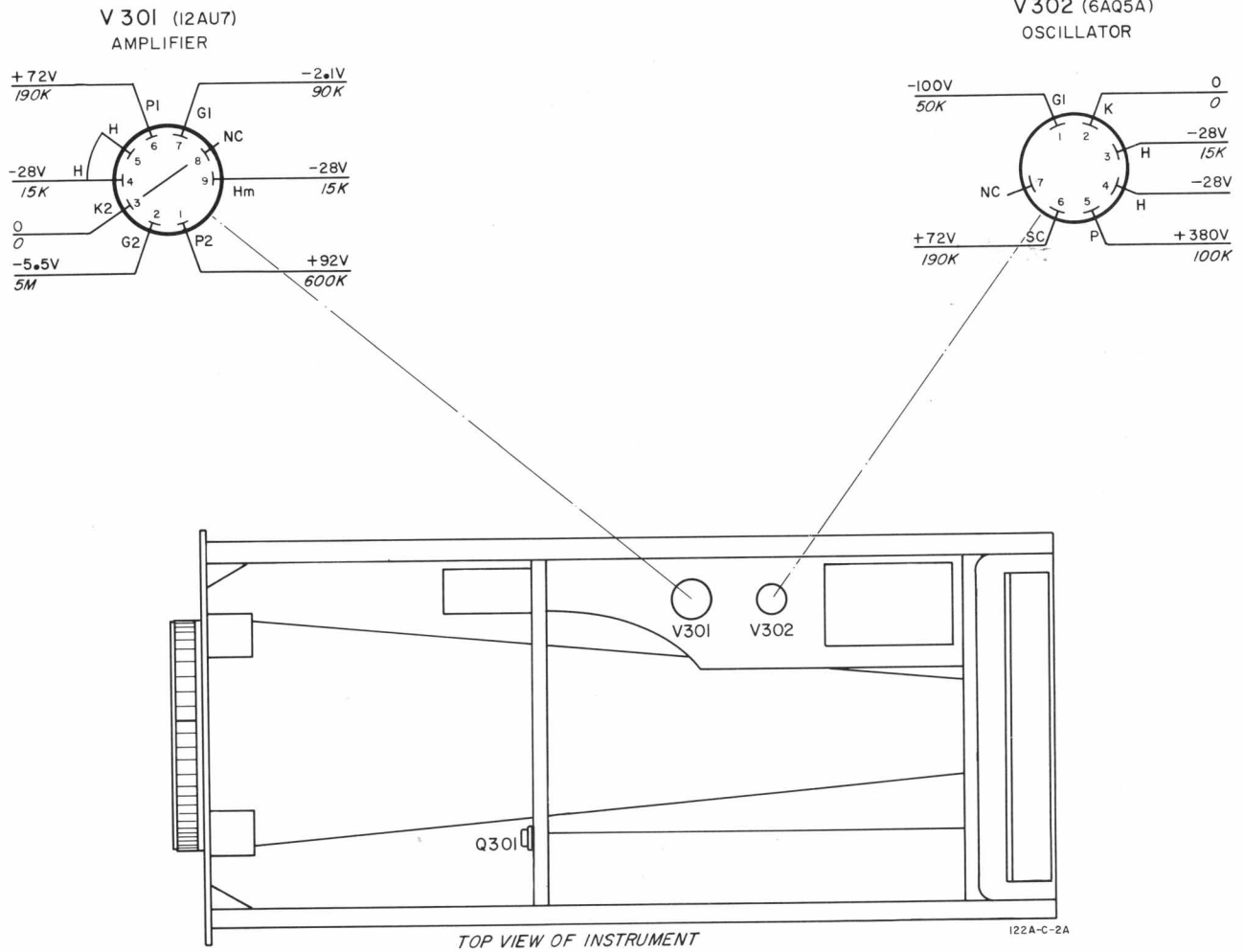
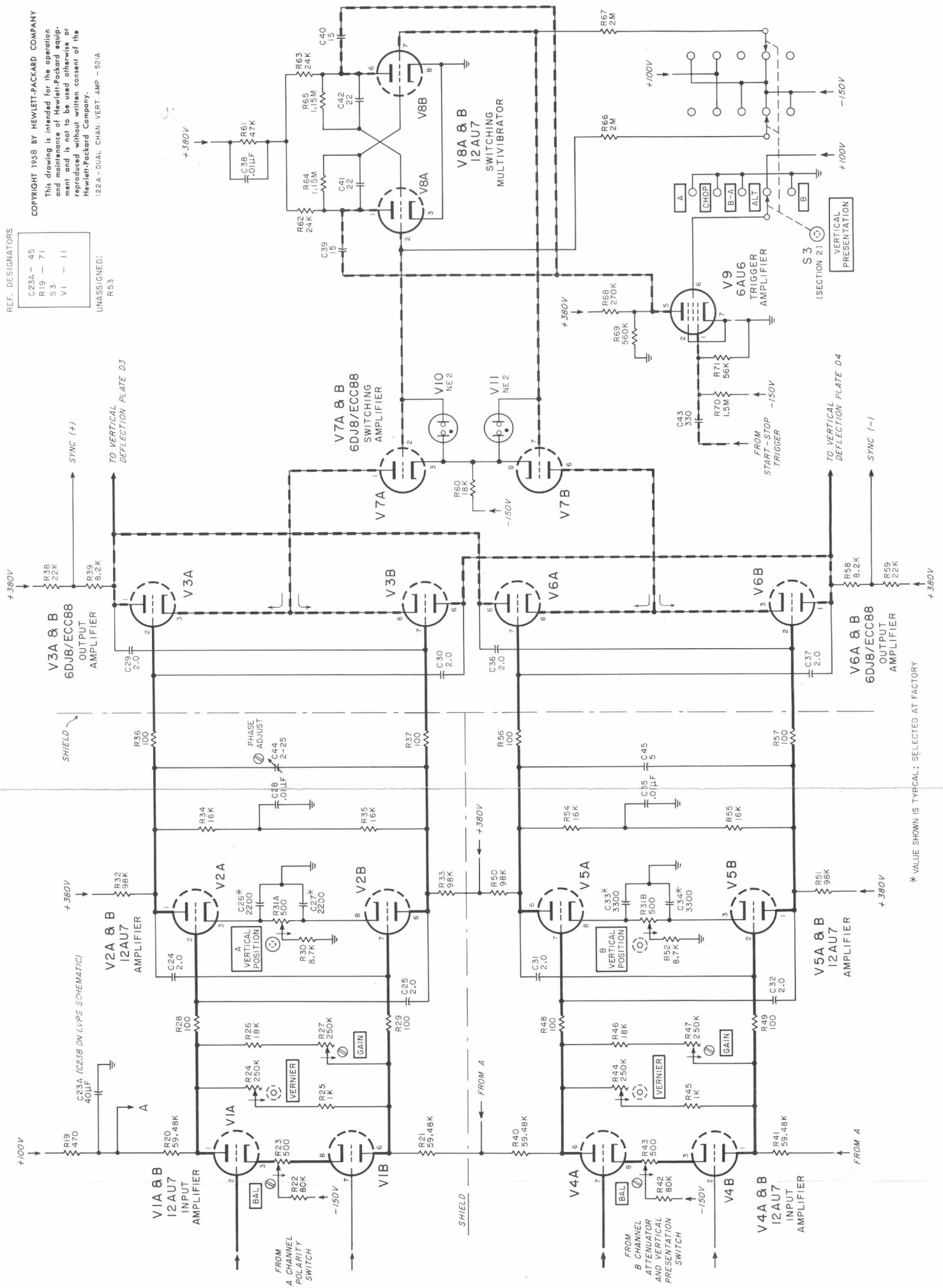

Figure 8-1. Top View Adjustment Location and Resistance Diagram

Figure 8-3



COPYRIGHT 1958 BY HEWLETT-PACKARD COMPANY
 This drawing is intended for the operation and maintenance of Hewlett-Packard equipment and is not to be used otherwise or reproduced without written consent of the Hewlett-Packard Company.
 122A - DUAL CHANNEL VERT. AMP - 521A

REF. DESIGNATORS

C23A - 45
R19 - 71
S3
V1 - 11

UNASSIGNED:
R53

* VALUE SHOWN IS TYPICAL; SELECTED AT FACTORY

Figure 8-3. Vertical Amplifier

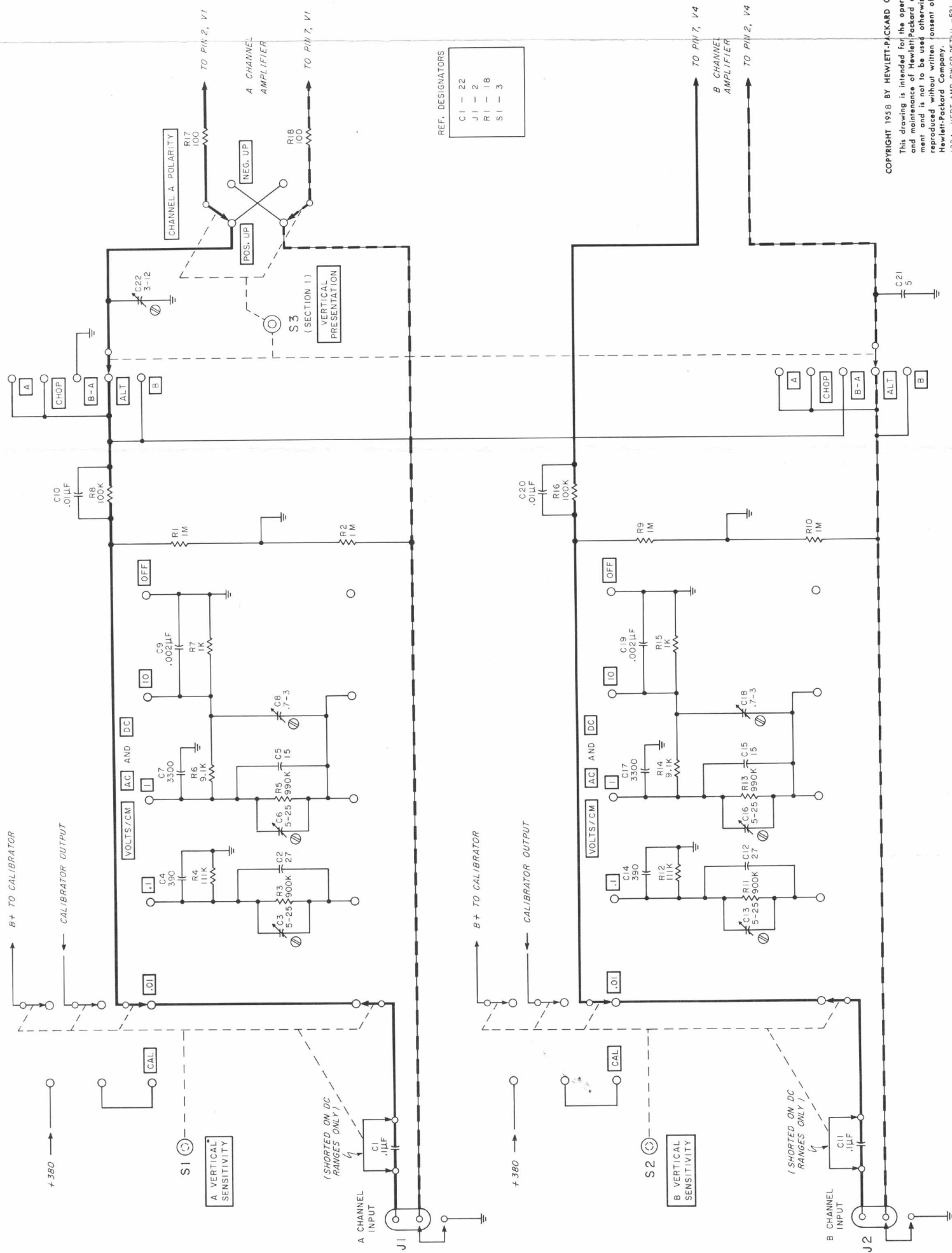

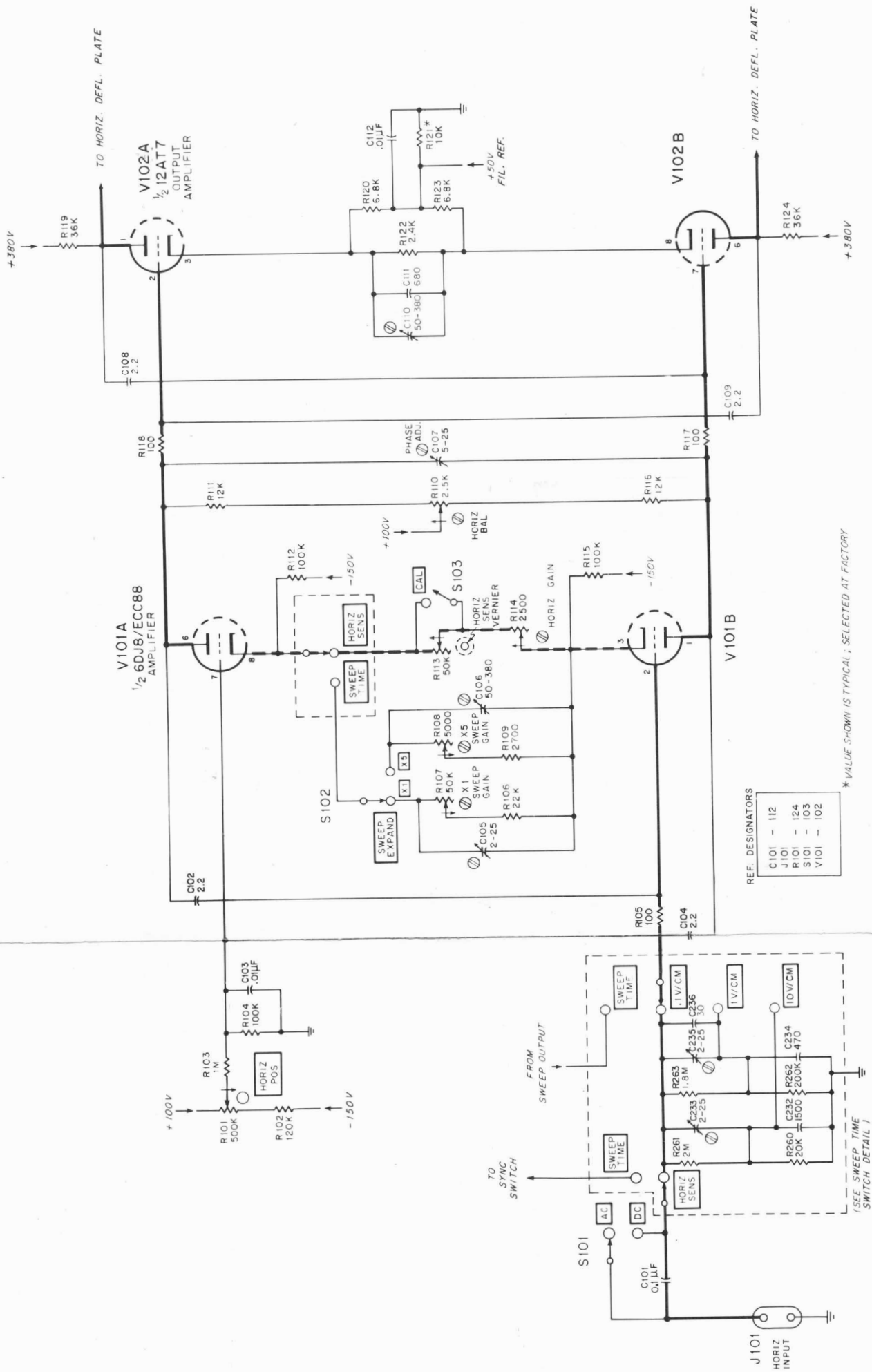

COPYRIGHT 1956 BY HEWLETT-PACKARD COMPANY
 This drawing is intended for the operation and maintenance of Hewlett-Packard equipment and is not to be used otherwise or reproduced without written consent of the Hewlett-Packard Company.

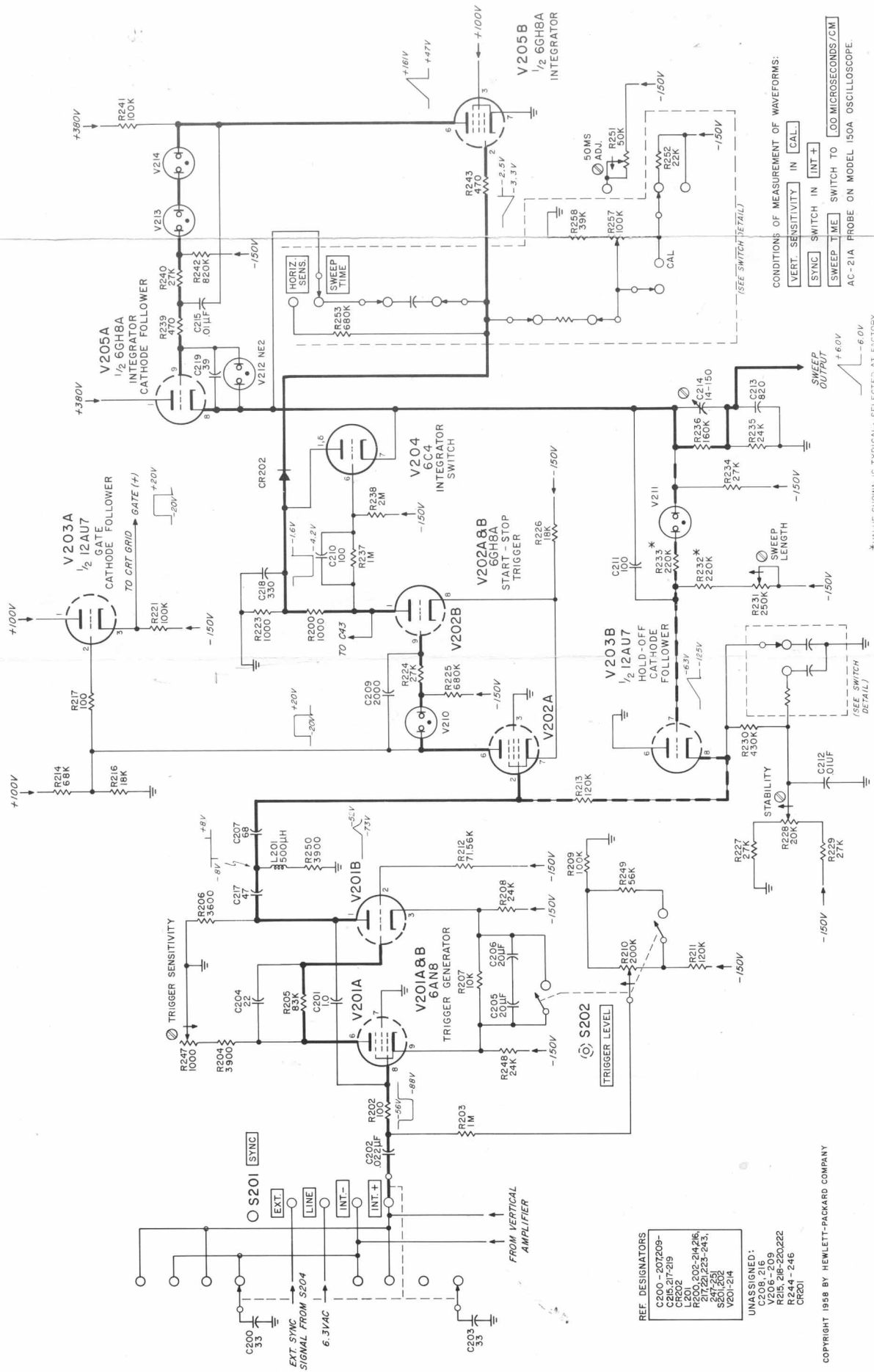

REF DESIGNATORS

C200	-207209-
C215	217-219
CR202	L201
L201	202-214,26
R201	217,221,223-243,
R241	251
S201	214
V201	214

UNASSIGNED:
C208, 216
V206 - 209
R215, 216-220,222
CR244 - 246
CR251

COPYRIGHT 1958 BY HEWLETT-PACKARD COMPANY

122A - S6 - 1214

CONDITIONS OF MEASUREMENT OF WAVEFORMS:
 VERT. SENSITIVITY IN [CAL.]
 SYNC SWITCH IN [INT+]
 SWEEP TIME SWITCH TO [∞ MICROSECONDS/CM]
 AC-21A PROBE ON MODEL 150A OSCILLOSCOPE.

* VALUE SHOWN IS TYPICAL, SELECTED AT FACTORY

Figure 8-6. Sweep Generator 8-7

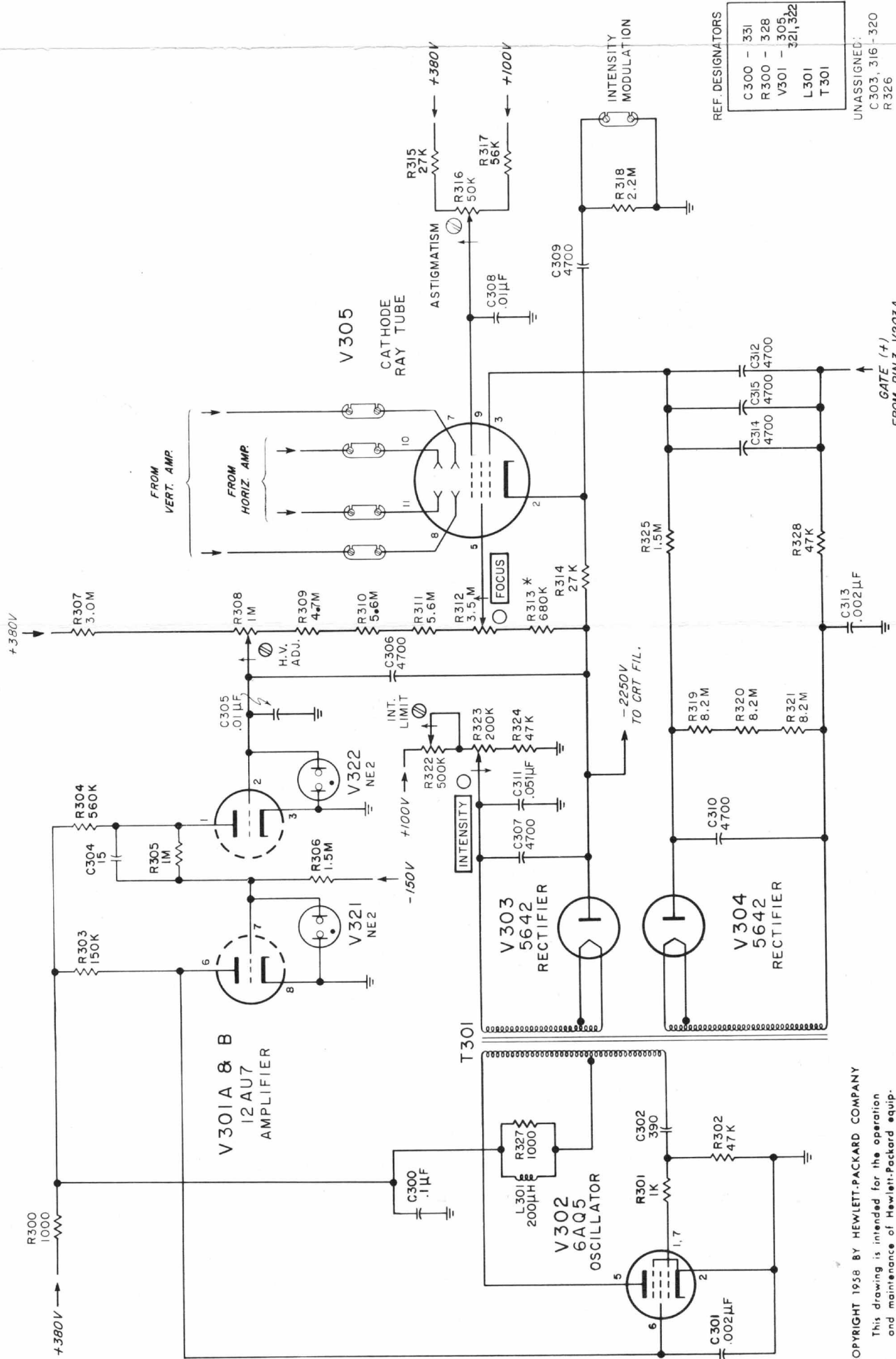

* VALUE SHOWN IS TYPICAL; SELECTED AT FACTORY

COPYRIGHT 1958 BY HEWLETT-PACKARD COMPANY
This drawing is intended for the operation and maintenance of Hewlett-Packard equipment and is not to be used otherwise or reproduced without written consent of the Hewlett-Packard Company.

122A - HVPS - 621A

FROM PIN 3, V203A
GATE (+)

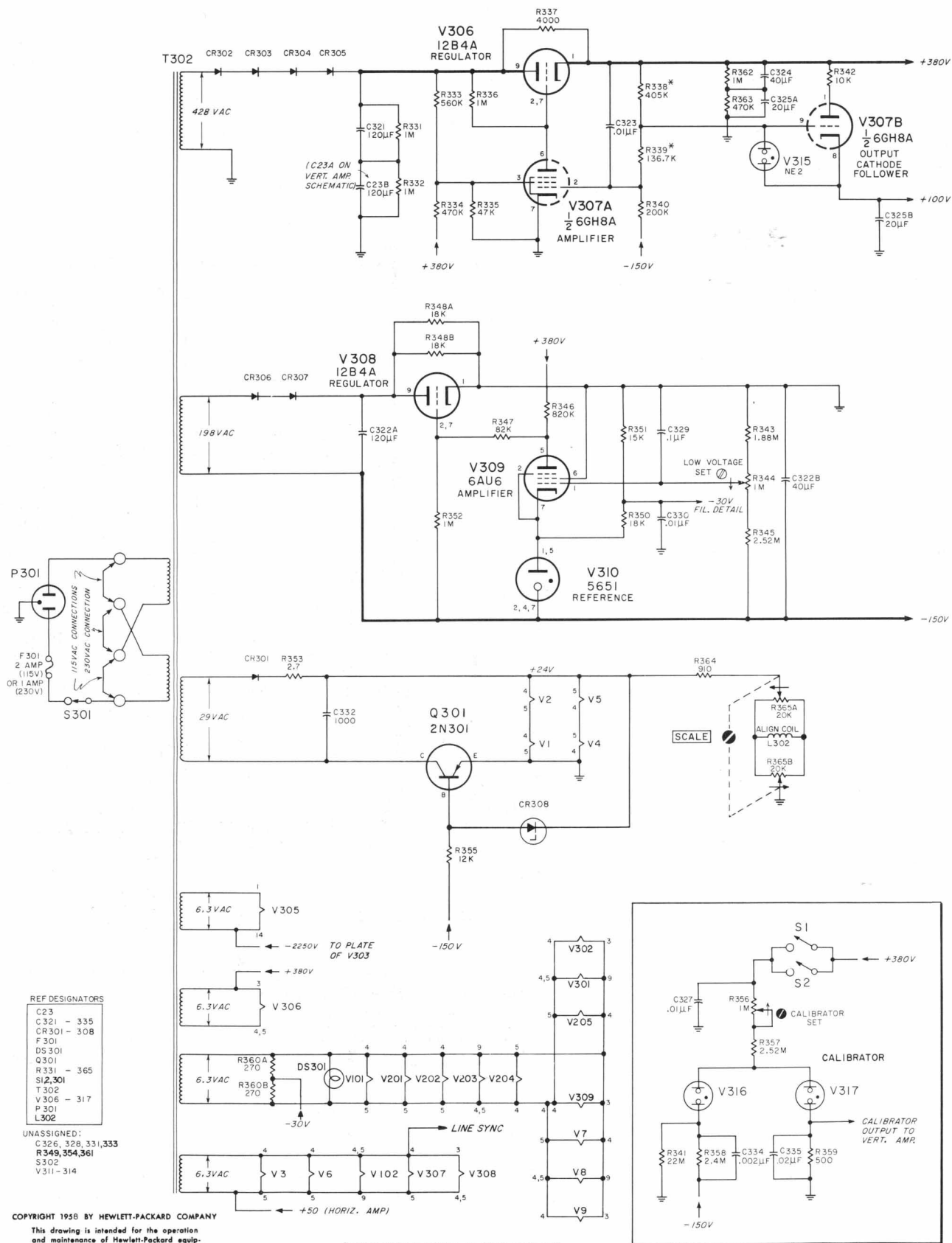

Figure 8-9. Low Voltage and Filament Supplies